

HARK Cookbook  
Version 3.3.0. (Revision: 9509)

HARK development team

# Contents

<b>1</b>	<b>Introduction</b>	<b>4</b>
<b>2</b>	<b>Learning HARK</b>	<b>6</b>
2.1	Learning sound recording . . . . .	6
2.2	Learning sound localization . . . . .	10
2.3	Learning sound separation . . . . .	15
2.4	Learning speech recognition . . . . .	18
<b>3</b>	<b>Something is Wrong</b>	<b>20</b>
3.1	Installation fails . . . . .	20
3.2	Sound recording fails . . . . .	22
3.3	Sound source localization fails . . . . .	23
3.4	Sound source separation fails . . . . .	25
3.5	Speech recognition fails . . . . .	26
3.6	Making a debug node . . . . .	27
3.7	Checking a microphone connection . . . . .	28
<b>4</b>	<b>Microphone Array</b>	<b>29</b>
4.1	Selecting the number of microphones . . . . .	29
4.2	Selecting the layout of the microphone array . . . . .	30
4.3	Selecting types of microphones . . . . .	31
4.4	Installing a microphone array in a robot . . . . .	32
4.5	Selecting a sampling rate . . . . .	33
4.6	Using an A/D converter unsupported by HARK . . . . .	34
<b>5</b>	<b>Input Data Generation</b>	<b>39</b>
5.1	Recording multichannel sound . . . . .	39
5.2	Recording impulse response . . . . .	42
5.3	Synthesizing multichannel sound from impulse response . . . . .	45
5.4	Adding noise . . . . .	46
<b>6</b>	<b>Acoustic and language models</b>	<b>47</b>
6.1	Creating an acoustic model . . . . .	47
6.1.1	Multi-condition Training . . . . .	47
6.1.2	Additional Training . . . . .	55
6.1.3	MLLR/MAP Adaptation . . . . .	55
6.2	Creating a language model . . . . .	56
<b>7</b>	<b>HARK-Designer</b>	<b>58</b>
7.1	Running the network from the command line . . . . .	58
7.2	Copying nodes from other network files . . . . .	60
7.3	Making an iteration using HARK-Designer . . . . .	61

<b>8</b>	<b>Sound source localization</b>	<b>62</b>
8.1	Introduction . . . . .	62
8.2	Tuning parameters of sound source localization . . . . .	64
8.3	Using part of a microphone array . . . . .	66
8.4	Localizing multiple sounds . . . . .	67
8.5	Checking if sound source localization is successful . . . . .	68
8.6	Too many localization results / no localization results . . . . .	69
8.7	Localization results are fragmented / Isolated sounds are connected . . . . .	70
8.8	The beginning of the separated sound is ignored . . . . .	71
8.9	Localizing the height or distance of a source . . . . .	72
8.10	Saving the localization results to a file . . . . .	73
<b>9</b>	<b>Sound Source Separation</b>	<b>74</b>
9.1	Introduction . . . . .	74
9.2	Saving separated sounds to files . . . . .	75
9.3	Parameter tuning of sound source separation . . . . .	76
9.4	Sound source separation using only the microphone array layout . . . . .	78
9.5	Separating sounds with stationary noise . . . . .	79
9.6	Reducing noise leakage by post processing . . . . .	80
9.7	Separating a moving sound. . . . .	82
<b>10</b>	<b>Feature Extraction</b>	<b>83</b>
10.1	Introduction . . . . .	83
10.2	Selecting the threshold for Missing Feature Mask . . . . .	86
10.3	Saving features to files . . . . .	87
<b>11</b>	<b>Speech Recognition</b>	<b>88</b>
11.1	Making a Julius configuration file (.jconf) . . . . .	88
<b>12</b>	<b>Others</b>	<b>90</b>
12.1	Selecting window length and shift length . . . . .	90
12.2	Selecting the window function for MultiFFT . . . . .	91
12.3	Using PreEmphasis . . . . .	92
<b>13</b>	<b>Advanced recipes</b>	<b>93</b>
13.1	Creating a node . . . . .	93
13.2	Improving the processing speed . . . . .	118
13.3	Connecting HARK to the other systems . . . . .	119
13.4	Controlling a motor . . . . .	130
<b>14</b>	<b>Appendix</b>	<b>131</b>
14.1	Introduction . . . . .	131
14.1.1	Category of sample network . . . . .	131
14.1.2	Notation of document and method for execution of sample network . . . . .	132
14.2	Sound recording network sample . . . . .	133
14.2.1	Ubuntu . . . . .	133
14.2.2	Windows . . . . .	136
14.3	Network sample of sound source localization . . . . .	138
14.3.1	Offline sound source localization . . . . .	138
14.3.2	Online sound source localization . . . . .	139
14.4	Network sample of sound source separation . . . . .	142
14.4.1	Off line sound source separation . . . . .	142
14.4.2	Off-line sound source separation (with postprocessing by HRLE) . . . . .	143
14.4.3	Online sound source separation (with/without postprocessing by HRLE) . . . . .	143
14.5	Network samples of Feature extraction . . . . .	144

14.5.1	Introduction	144
14.5.2	MSLS	144
14.5.3	MSLS + $\Delta$ MSLS	146
14.5.4	MSLS+Power	146
14.5.5	MSLS+ $\Delta$ MSLS+Power+ $\Delta$ Power	148
14.5.6	MSLS+ $\Delta$ MSLS+ $\Delta$ Power	148
14.5.7	MSLS+ $\Delta$ MSLS+ $\Delta$ Power+Preprocessing	150
14.6	Speech recognition network sample	153
14.6.1	Running the speech recognition	153
14.6.2	Evaluating the speech recognition	154

# Chapter 1

## Introduction

This document describes frequently occurring problems and their solutions. Each problem-solution pair is called a “recipe“, which resembles the term “recipe“ used in cooking. (\*This document is mainly written for the HARK 2.5 or earlier, and has not maintained for a long time. Please bear this in mind when using the HARK 3.0 or later.)

### **Chapter 2: Learning HARK**

This chapter include recipes for beginners. These recipes describe methods of recording, localizing, separating and recognizing sound. It is recommended for first-time HARK users to read the recipes found in this chapter.

### **Chapter 3: Something is Wrong!**

This chapter describes troubleshooting common problems that occurs during installation and recording. It also includes debugging recipes. This can be used as reference in solving common problems.

### **Chapter 4: Microphone Array**

This chapter include recipes on the layout of microphone arrays. Use this chapter as reference when the problem occurring is related to the number of microphones, type of microphones, or in the set-up of microphones in robot systems.

### **Chapter 5: Input Data Generation**

This chapter include recipes for generating input data in HARK. Basically, it has recipes for multi-channel recording, impulse response measurements, and also multichannel sound generated through simulation.

### **Chapter 6: Acoustic and Language Models**

This chapter describes how to build an acoustic model and a language model, which is a requirement in using the speech recognition software Julius supported by HARK.

### **Chapter 7: HARK-Designer**

The robot audition system in HARK is created through a network generation GUI ‘HARK-Designer‘ by placing and connecting nodes. This chapter include recipes in using HARK-Designer.

### **Chapter 8: Sound Source Localization**

This chapter include recipes for sound source localization. It covers the recipes in building sound source localization system, parameter tuning, as well as debugging.

### **Chapter 9: Sound Source Separation**

This chapter include recipes for sound source separation. Similar to sound source localization, this covers the recipes in system building, parameter tuning, and debugging.

### **Chapter 10: Feature Extraction**

Speech recognition requires the extraction of features from separated sound. This chapter include recipes on the introduction and extraction of features used in speech recognition It also include recipes of Missing Feature Theory used to select reliable features.

**Chapter 11: Speech Recognition**

This chapter include recipes on how to make a configuration file for Julius .

**Chapter 12: Others**

This chapter include recipes that are not found in other chapters, such as selecting a window function for frequency analysis.

**Chapter 13: Advanced recipes**

This chapter include advanced recipes, such as new functions added to HARK and connecting HARK to other systems.

**Chapter 14: Sample Networks**

This chapter include various sample network files. These samples can be used as reference in creating a network.

# Chapter 2

## Learning HARK

### 2.1 Learning sound recording

#### Problem

I want to record sound using HARK. This is the first time I am using HARK.

#### Solution

For first-time HARK users, it is best to start recording first because this is a basic function and also inevitable in running HARK online. It is convenient to use `wios` if the aim is to simply record a sound. See HARK document or [Recording multichannel sound](#) for details.

#### Recording device :

For a start, get a recording device. The microphone input in computers may be used, but a multichannel recording device is needed to localize or separate sounds. (see the chapter on devices in the HARK document in details).

From here, it is assumed that the device used is ALSA. Try to run the following commands:

```
arecord -l
```

A list of connected devices will then be displayed:

```
card 0: Intel [HDA Intel], device 0: AD198x Analog [AD198x Analog]
  Subdevices: 2/2
  Subdevice #0: subdevice #0
  Subdevice #1: subdevice #1
card 1: ** [***], device 0: USB Audio [USB Audio]
  Subdevices: 1/1
  Subdevice #0: subdevice #0
```

Find the name of the device from the list. In case the device is not on the list, it means that the OS does not recognize the device. If the device is on the list, the device name will be specified by two numbers, the card number and the subdevice number.

For example, if the device used is USB Audio as shown above, the card number is `#1` and the subdevice number is `#0`. In this case the device name will be `plughw:1,0`. If the device is unknown, try `plughw:0,0`.

Devices that supports DirectSound and ASIO can be used in Windows. A list of devices that can be used in HARK can be checked through: [Start] – [Programs] – [HARK] – [Sound Device List]

It can also be checked by executing the following in the command prompt:

```
SoundDeviList
```

For devices that support DirectSound, the parameters of `AudioStreamFromMic` `DEVICETYPE` should be set to “DS“ and `DEVICE` to the device name. Although multibyte string device name is not supported, a part of the device name is searched so it is possible to input only a part of the device name.

For devices that supports ASIO, install the “ASIO Plugin for HARK“ and use the `AudioStreamFromASIO` node. Similar to the `AudioStreamFromMic`, input the device name in the parameter.

If the `AudioStreamFromASIO` is not found in the Node List of HARK Designer, select the `libasio-plugin.def` from the packages in [Preference] – [Packages].

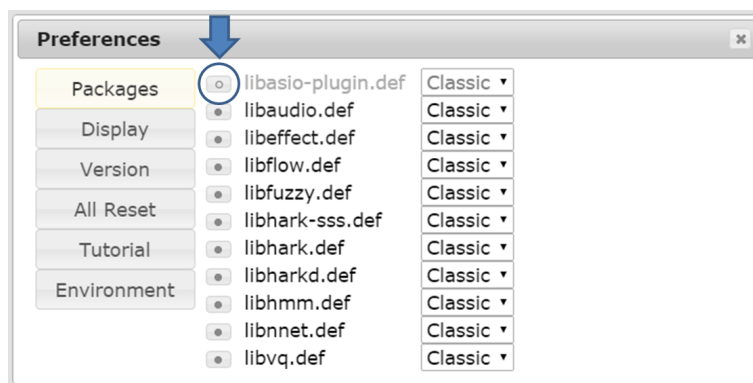

Figure 2.1: ASIO Plugin for HARK

### Building a recording network :

Next is to build a recording network using HARK-Designer. The topology of the network is the same as shown in Fig.2.2 and 2.3. Although you can leave almost all parameters to their default settings, it is also possible to change the parameters as shown in 2.1.

Check the specifications of the device to determine the number of channels and the sampling frequency. Identifying the device name is explained in the section above. The number of recording frames will depend on the recording time of the sound. This can be calculated using the equation:

$$Recording\ time = (LENGTH + (frames - 1) * ADVANCE) / SAMPLING\_RATE \quad (2.1)$$

where the uppercase variables are the parameters of `AudioStreamFromMic` . For example, if the recording time is 5 seconds at 16kHz sampling frequency with the `LENGTH` and `ADVANCE` set to default, the number of frames will be 498 because:

$$5[sec] = (512 + (frames - 1) * 160) / 16000 \quad (2.2)$$

### Running the network :

Now, Execute the network. Multiple files such as `sep_0.wav`, `sep_1.wav`,..., will be generated with the number of files being the same as the number of channels. Play the files using audio players such as `aplay`

```
aplay sep_0.wav
```

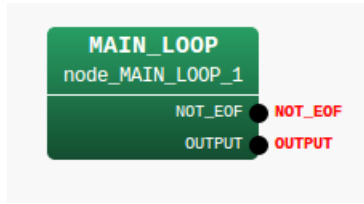

Figure 2.2: MAIN (subnet)

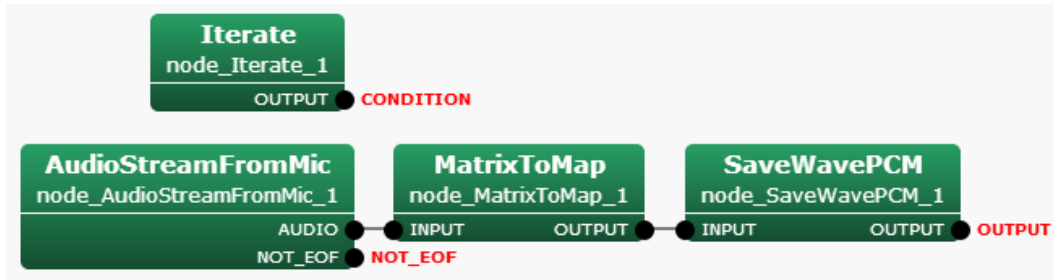

Figure 2.3: MAIN\_LOOP (iterator)

Table 2.1: Parameters to configure

Node name	Parameter name	Type	Meaning
Iterate	MAX_ITER	int	Number of frames to record(498)
AudioStreamFromMic	CHANNEL_COUNT	int	Number of channels you use(8)
AudioStreamFromMic	SAMPLING_RATE	int	Sampling rate(16000)
AudioStreamFromMic	DEVICETYPE	string	Type of device(ALSA)
AudioStreamFromMic	DEVICE	string	Device name(plughw:0,0)

### Troubleshooting :

If the recording is successful, congratulations! But if not, check the problem by following the instructions below, or consult the recipe here: [Sound recording fails](#).

#### Microphone connection:

Is the microphone connected properly? Try to unplug and plug in again the microphone.

#### Plug-in power:

Does the microphone need plug-in (external) power? Check if the battery has enough power and if the switch is on.

#### Use other recording software:

Try to record by using other recording software such as wavesurfer or audacity. If it still fails, check the configuration of the OS, the driver, or the device itself.

#### Device name:

If the computer is connected to multiple sound devices, confirm the device name of the recording device used. Then check again using `arecord -l` or try other device names.

### Discussion

`SaveWavePCM` is the easiest way to record a sound. However, `SaveRawPCM` can be used to save waveform without headers. `SaveRawPCM` is saved as a raw file with 16 bit little-endian format and the file extension is “.sw” Fig. 2.4 shows the subnetwork using the node.

Raw file can be read using programming languages such as python modules `numpy` and `pylab` :

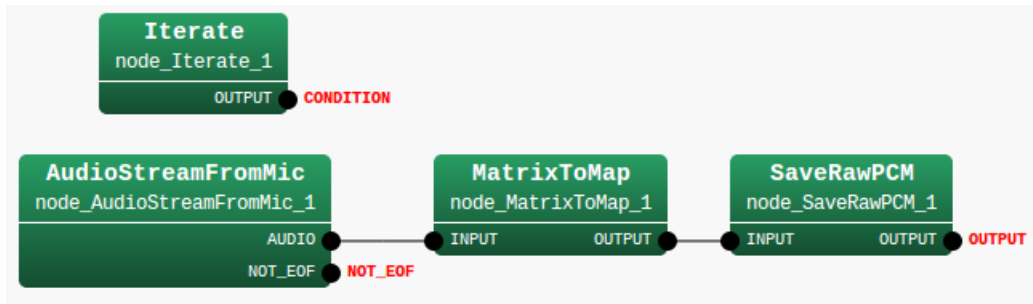

Figure 2.4: MAIN\_LOOP (iterator subnetwork)

```
import numpy, pylab
waveform = numpy.fromfile("sep_0.sw", numpy.int16)
pylab.plot(waveform)
pylab.show()
```

Raw file can be played using `aplay`:

```
aplay -c 1 -r 16000 -f S16_LE sep_0.sw
```

Raw files (.sw) can be converted to a wave file by using `sox`. For example, to convert `sep_0.sw` recorded with 16bit, 16kHz sampling, run the following command to get `sep_0.wav`

```
sox -r 16000 -c 1 --bits 16 -s sep_0.sw sep_0.wav
```

See Also

The chapter on devices in the HARK document, as well as the recipe [Sound recording fails](#), are relevant. See the recipe: [Recording multichannel sound](#) for sound recording using `wios`.

See the HARK document for details of nodes and parameters in the network files.

## 2.2 Learning sound localization

### Problem

I want to perform source localization in HARK but I don't know where to start.

### Solution

#### (1) Source localization of an audio file

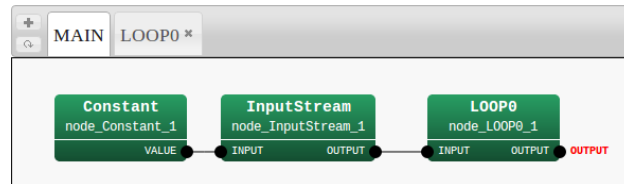

(a) MAIN Subnetwork

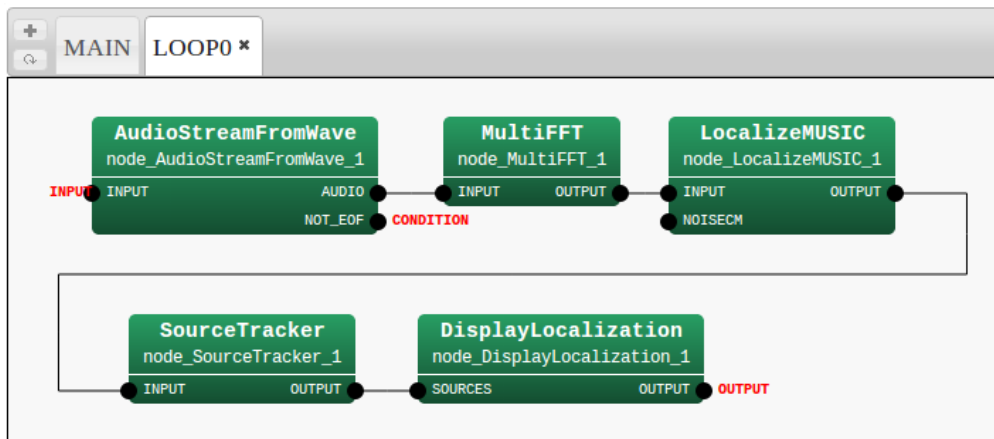

(b) Iterator Subnetwork

Figure 2.5: HARK network file for sound source localization using a .wav file

Fig. 2.5 shows an example of a HARK network file for sound source localization using a .wav file input. The .wav file contains multi-channel signals recorded by a microphone array. In the network file, it localizes sound sources and displays their locations.

For the node property settings in the network file, see Section 6.2 in the HARK document.

Samples of HARK network file including sound source localization are provided in [Samples](#).

For the first simple test, download “HARK Automatic Speech Recognition Pack” containing the version of HARK you are using or the model you want to use. Unzip the downloaded file and type the following command in the unzipped directory.

```
harkmw sep_rec_offline.n 2SPK-jp.wav
```

The localization result will then be displayed, as shown in Fig. 2.6. If the window and the localization result is displayed, it means that the network is working correctly.

#### (2) Real time sound source localization from a microphone

Fig. 2.7 shows an example of a HARK network file for real-time sound source localization using a microphone array.

Here, `AudioStreamFromWave` in Fig. 2.5 is replaced by `AudioStreamFromMic`. By properly setting the parameters in `AudioStreamFromMic`, a sound source can be localized in real time using a microphone array. For the setting of these parameters, see Section 6.2 in the HARK document. If the network file works

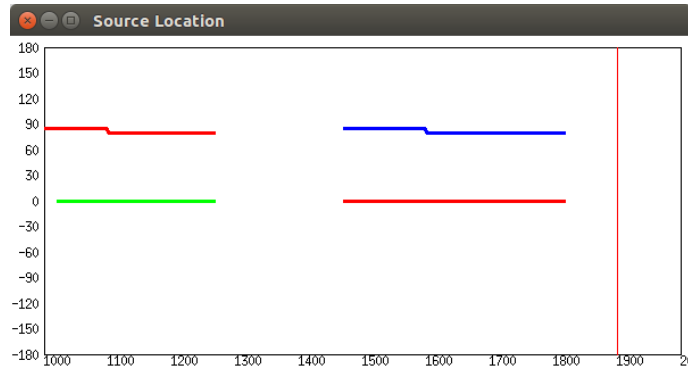
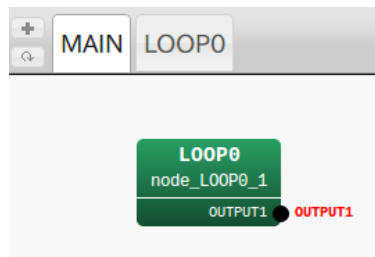
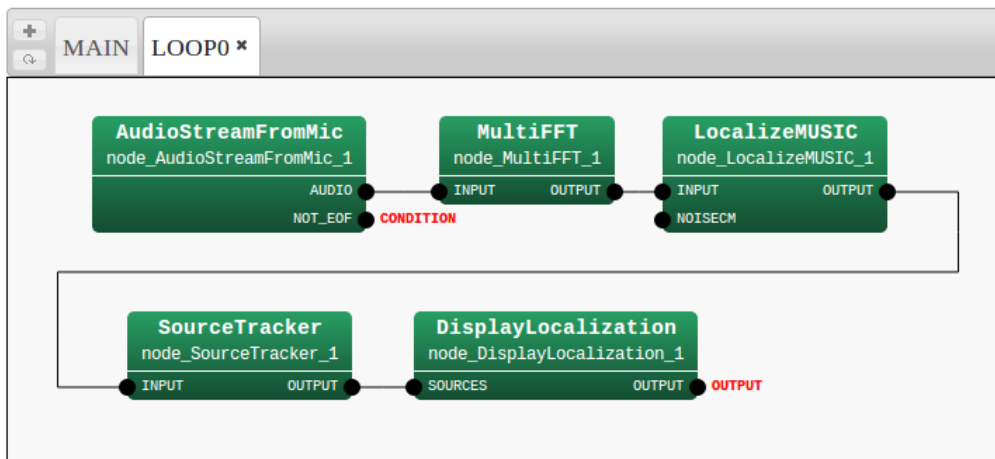

Figure 2.6: Snapshot of the sound source localization result using `sep_rec_offline.n`



(a) MAIN Subnetwork



(b) Iterator Subnetwork

Figure 2.7: HARK network file for sound source localization using a microphone array

properly, the localization result is displayed as in Fig. 2.6. If it does not work properly, read , “[Sound recording fails](#)” or “[Sound source localization fails](#)”

### (3) Sound source localization with suppression of constant noise

The sound source localization shown in Fig. 2.5 and Fig. 2.7 can not determine which sound sources are desired. If there are several of high power noise in the environment, `LocalizeMUSIC` will only localize noise. In the worst case, it cannot localize speech, resulting in a drastic degradation of performance of automatic speech recognition.

This is especially true for automatic speech recognition by a robot-embedded microphone array, in which there are several sources of high power noise related to the robot motor and fan, degrading the performance

of the entire system.

To solve this problem, HARK supports the pre-measured noise suppression function in sound source localization. There are 2 steps to enable this function:

- 3-1) Generation of pre-measured noise files for localization
- 3-2) Sound source localization with these noise files

The next two section explain (3-1) and (3-2), respectively.

**(3-1) Generation of pre-measured noise files for localization**

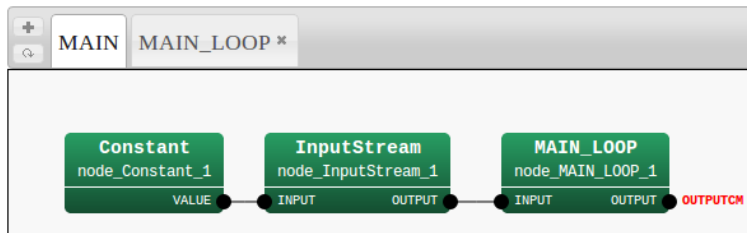

(a) MAIN Subnetwork

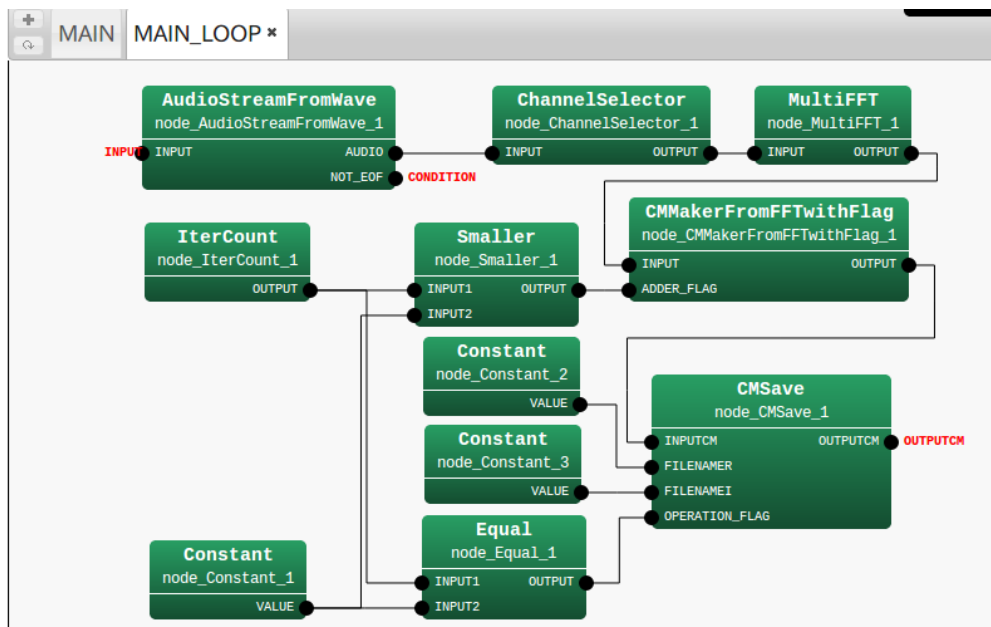

(b) Iterator Subnetwork

Figure 2.8: HARK network file for generating the noise files for sound source localization

Fig. 2.8 shows an example of a HARK network file for generating a pre-measured noise file for sound source localization. To set the parameter of the HARK nodes, see Section 6.2 in the HARK document. The Iterator (LOOP0) subnetwork in Fig. 2.8 has 3 Constant nodes, an IterCount node, a Smaller node, and an Equal node. The parameter settings for those nodes are:

- node\_Constant\_1
  - **VALUE**  
int type. VALUE = 200.  
This represents the frame length used to generate the noise file from the first frame.
- node\_Constant\_2

- **VALUE**  
string type. VALUE = NOISEr.dat.  
File name for the real part of the noise file.
- node\_Constant\_3
  - **VALUE**  
string type. VALUE = NOISEi.dat.  
File name for the imaginary part of the noise file.
- node\_IterCount\_1
  - No parameter  
This outputs the index of the HARK processing frames
- node\_Smaller\_1
  - No parameter  
This determines the index of HARK processing frames is larger than a specific number.
- node\_Equal\_1
  - No parameter  
This determines if the index of HARK processing frames is equal to a specific number.

Here, the `node_Constant_1` VALUE is set to 200. The `MAX_SUM_COUNT` in `CMMakerFromFFTwithFlag` is then set to a value greater than 200.

This network file utilizes a `.wav` file input containing only noise. Depending on the VALUE of `node_Constant_1`, this node generates noise file for certain frames.

When the network file is executed, two files will be generated in the current working directory which are `NOISEr.dat` and `NOISEi.dat`. These two files are used for sound source localization with noise-suppression function.

In this example, 200 frames is used from the first frame to generate the noise file. By using conditions other than those of the `Smaller` node, the frame to be used for generation can be specified.

### (3-2) Sound source localization with the noise files

Fig. 2.9 shows an example of a HARK network file for sound source localization using noise files generated in (3-1), `NOISEr.dat` and `NOISEi.dat`. For the parameter settings of the HARK nodes, see Section 6.2 of the HARK document. The Iterator (`LOOP0`) subnetwork in Fig. 2.9 has 3 Constant nodes, and the parameter setting for those nodes are:

- node\_Constant\_1
  - **VALUE**  
string type. VALUE = NOISEr.dat.  
File name for the real part of the loaded noise file.
- node\_Constant\_2
  - **VALUE**  
string type. VALUE = NOISEi.dat.  
File name for the imaginary part of the loaded noise file.
- node\_Constant\_3
  - **VALUE**  
int type. VALUE = 0.  
This enables updating noise information every frame. If 0, the noise files are loaded only at the first frame.

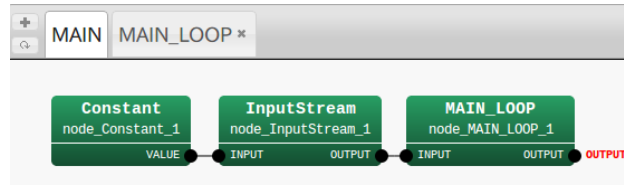

(a) MAIN Subnetwork

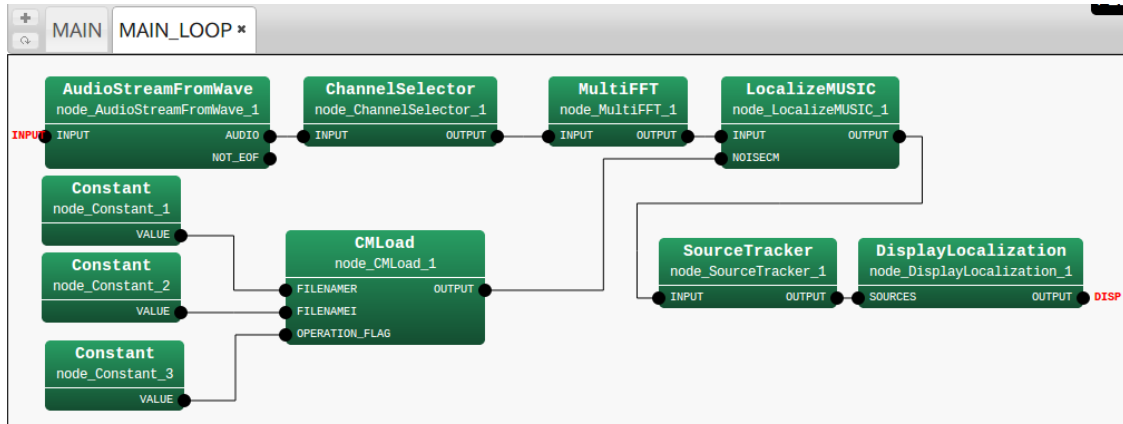

(b) Iterator Subnetwork

Figure 2.9: HARK network file for sound source localization with pre-measured noise suppression

CMLoad reads the noise files, NOISEr.dat and NOISEi.dat, and whitens the noise in sound source localization. To enable the noise suppression function, set MUSIC\_ALGORITHM in LocalizeMUSIC to GEVD or GSVD. The details of the algorithm for the noise suppression are described in Section 6.2 of the HARK document.

When the HARK network file is executed, the sound source localization results will be displayed, similar with Fig. 2.6. Compared with localization without noise suppression, it is noticeable that there is greater focus on speech localization.

### Discussion

For all the details about the algorithm and noise suppression in LocalizeMUSIC, see Section 6.2 in the HARK document. To increase accuracy, read the recipe in Chapter 8 or the descriptions of the nodes LocalizeMUSIC and SourceTracker in the HARK document and tune it.

### See Also

[Sound recording fails](#), [Sound source localization fails](#)

## 2.3 Learning sound separation

### Problem

I want to separate a sound signal coming from a specific location.

### Solution

To perform sound source separation in HARK, a network file and a binary format transfer function called HGTF(binary format) which is used in the separation module GHDSS, or a microphone position file (HARK text file) are necessary.

The following 4 items are required in the creation of a network file for sound source separation:

#### Audio signal acquisition:

AudioStreamFromMic or AudioStreamFromWave node is used to input audio signal.

#### Source location:

ConstantLocalization , LoadSourceLocation , or LocalizeMUSIC node is used to specify the location of the desired audio to be separated. Use ConstantLocalization node to perform simple source separation, or use LocalizeMUSIC node to perform separation while doing online localization.

#### Sound source separation:

The GHDSS is the node used for sound source separation. The input consists of source location and the audio signal. The output is the separated signal. The GHDSS node requires a transfer function, which is stored as an HGTF binary format file or calculated from a microphone position file.

#### Saving the Separated signal:

Since a separated signal is in the frequency domain, the user must use the Synthesize node to revert it back to time domain before using the SaveRawPCM or SaveWavePCM node to save the output.

Post-processing of the separated signal can be performed in HARK. It is not really necessary to do post-processing, but it may be needed depending on the environment or the purpose of using the separated signal.

#### Post-processing :

Noise suppression can be applied to the separated signal by using the PowerCalcForMap , HRLE , CalcSpecSubGain , EstimateLeak , CalcSpecAddPower , and SpectralGainFilter nodes.

Figure 2.10, 2.11, and 2.12 are images of sample networks. Fig.2.11 shows a sound source without post-processing, while Fig. 2.12 shows a sound source with post-processing. Sound source separation can be performed by connecting a GHDSS node in the network file created in the [Learning sound localization](#). Then set the HGTF or the microphone position file in the parameters. However, to be able to listen to the separated signal, Since the output is in the frequency domain, use the Synthesize node to revert it back to time domain before saving it using the SaveRawPCM or SaveWavePCM node.

When executing these networks, simultaneous speech from two speakers are separated and saved in sep\_0.wav, sep\_1.wav, ...

### Discussion

#### Offline / Online :

For online separation, replace the AudioStreamFromWave with the AudioStreamFromMic node.

#### Specific direction / Estimated direction :

By connecting the output of LocalizeMUSIC node to the INPUT\_SOURCES input of GHDSS node, the estimated direction of the sound source can be used in sound source separation. When it is

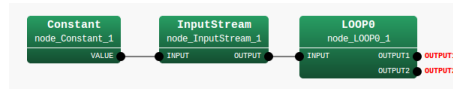

Figure 2.10: MAIN

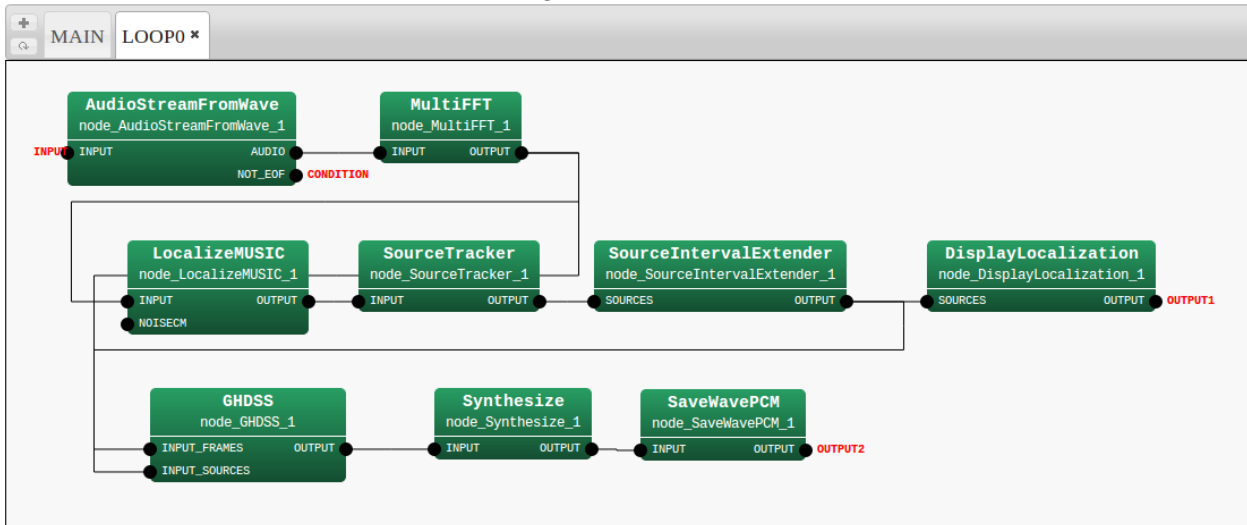

Figure 2.11: MAIN\_LOOP (without post-processing)

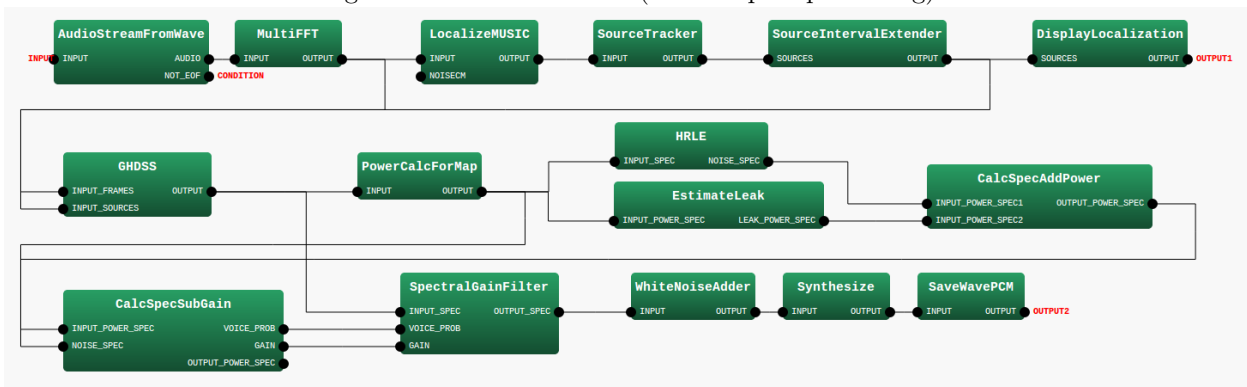

Figure 2.12: MAIN\_LOOP (with post-processing)

connected to ConstantLocalization node, only a specific direction will be separated. In addition, when the output of LocalizeMUSIC is stored using the SaveSourceLocation node, it can be loaded using the LoadSourceLocation node.

### Measurement-based / Calculation-based transfer function :

The input of the parameters should be set according to the transfer function to be used. To use a measurement-based transfer function, TJ\_CONJ is set to "DATABASE", and TJ\_CONJ.FILENAME is set to the file name of the transfer function. To use a microphone direction calculation-based transfer function, TJ\_CONJ is set to "CALC", and MIC\_FILENAME is set to the file name of the transfer function. To change the device besides Kinect, or to change the position of the microphone array, a different localization and separation transfer function is necessary.

Each parameter in the sample is already tuned in advanced, so there is a possibility that the performance of sound source separation will deteriorate because of differences in the environment. To know more about parameter tuning, see [Sound Source Separation](#).

### See Also

To know more about transfer function and microphone position files, see the file format chapter of HARK document. If there are problems with the separation process, see “[Sound source separation fails](#).” Since sound source separation comes after the source localization process, it is important to confirm if the process before sound recording or source localization are performed correctly. For sound recording and source localization, the recipes: “[Learning sound recording](#)”, “[Learning source localization](#)”, “[Sound recording fails](#)” and “[Sound source localization fails](#)” may be helpful.

## 2.4 Learning speech recognition

### Problem

This is the first time I am trying to recognize speech with HARK.

### Solution

Speech recognition with HARK consists of two main processes.

1. Feature extraction from an audio signal with HARK
2. Speech recognition with JuliusMFT

Each file and parameter settings necessary for this process is complex, so instead of creating from scratch, it is better to modify the sample networks and apply the appropriate changes directly, as shown in [Appendix](#).

### Feature extraction :

This section describes the instruction on how to create a network for the extraction from speech of features supported by HARK, which are MSLS and MFCC. Specifically the creation of network that extract commonly used features such as MSLS,  $\Delta$  MSLS, and  $\Delta$  power or MFCC,  $\Delta$  MFCC, and  $\Delta$  power

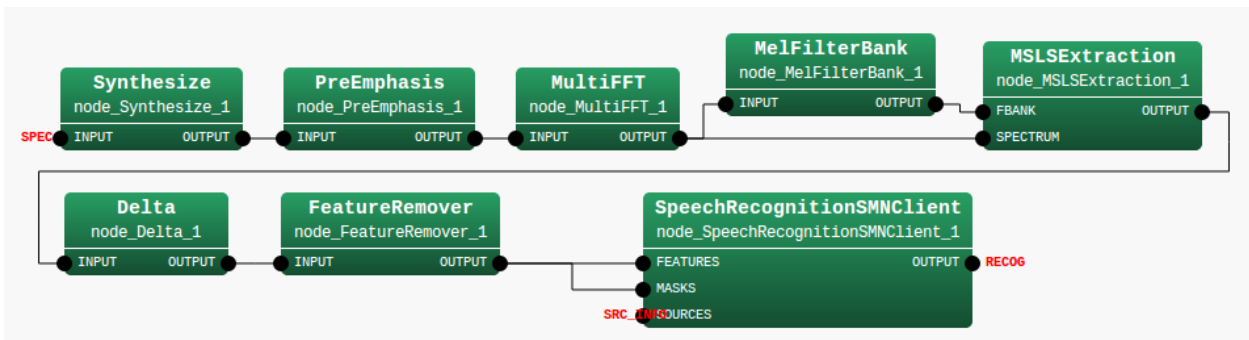

Figure 2.13: MSLS

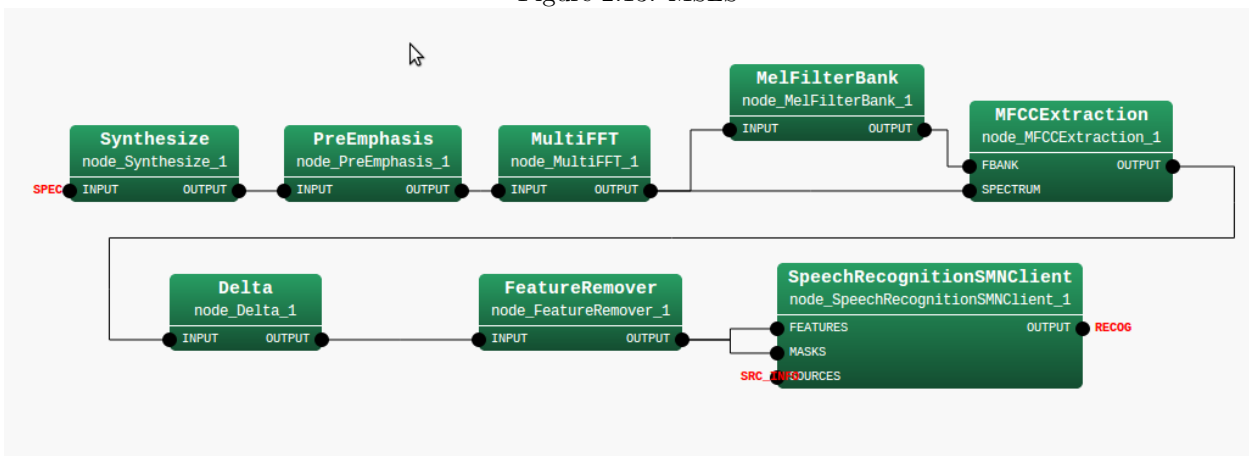

Figure 2.14: MFCC

Figure 2.13 and 2.14 shows network files to extract MSLS and MFCC features, respectively. PreEmphasis , MelFilterBank , Delta , FeatureRemover and either MSLSExtraction orMFCCExtraction nodes are used to

extract the features. The `SpeechRecognitionClient` node sends the extracted feature to `JuliusMFT` by socket connection. Other than the input of the features, the sound source localization result is also necessary for the speech recognition of each sound source.

If it is possible to check if the extraction of the features is successful by saving the features in a file using the `SaveFeatures` and `SaveHTKFeatures` node.

### Speech Recognition :

`JuliusMFT` , which is based on the speech recognition engine `Julius`, is used for speech recognition. For users that has no experience in using `Julius`, see [Julius website](#) to learn the basic usage of `Julius`.

It is necessary to set the input format of the file settings to “mfcnet“ in order to receive and recognize the features extracted through `HARK` by socket connections. Below is an example of the settings:

```
\begin{verbatim}
-input mfcnet
-pluginindir /usr/lib/julius\_plugin
-notypecheck
-h hmmdefs
-hlist triphones
-gram sample
-v sample.dict
\end{verbatim}
```

The first three lines above are necessary to receive features from `HARK`.

Line 1 to receive features from the socket connection,

Line 2 for setting the installation path of the plugin that enables the use of socket connection,

Line 3 for type check in `JuliusMFT` of `MSLS` feature extracted with `HARK`.

The “-pluginindir” option must be set correctly according to the environment.

### Discussion

The simplest method consists of:

- Read monaural sound using `AudioStreamFromMic` node
- Connect the output of the `AudioStreamFromWave` node to the input of the `PreEmphasis` node (in time domain), as shown in [Figure 2.13](#)

To recognize separated sound, connect the output of the `GHDSS` node (in frequency domain) to the `Synthesize` node as shown in [Figure 2.13](#) or [2.14](#).

### See Also

Since the usage of `JuliusMFT` is mostly the same with `Julius`, the [Julius website](#) can be used for reference. To learn more about the features or models used in `JuliusMFT` , see [Feature extraction](#) or [Acoustic and Language Models](#).

To perform sound source localization and/or sound source separation, see the following recipes: [Sound recording fails](#), [Sound source localization fails](#), [Sound source separation fails](#), and [Speech recognition fails](#)

# Chapter 3

## Something is Wrong

### 3.1 Installation fails

#### Problem

The standard method of installing HARK is adding the HARK repository using the [HARK installation instructions](#), and running

```
sudo apt install hark-base harkmw hark-core
sudo apt install hark-designer
sudo apt install harktool5 harktool5-gui
sudo apt install kaldidecoder-hark
```

This recipe should be used if the above procedure does not work.

#### Solution

To install HARK to an unsupported OS, it must be compiled from its source. See the section on Installation from Source Compilation in [HARK installation instructions](#), then download the source, compile, and install.

If installation fails, the remaining HARK files such as its library, will remain in the old version. Uninstall all HARK-related software, then reinstall.

If compiling from the source, execute the following command to delete it.

```
make uninstall # remove copied files
make clean
# remove compiled files
make distclean # remove Makefile
```

To check if the old HARK has been properly deleted, execute `batchflow` in a command line. If successfully deleted, the error, “The command is not found”, will be displayed. Execute `ls /usr/local/lib/python3.5/dist-packages` and confirm that the `harkmw-3.0.0-py3.5-linux-x86_64.egg` directory has been deleted. If it is still there, delete it. Because python version(3.5) and HARK version(3.0.0) may vary depending on your environment, replace as appropriate.

#### Discussion

Major problems with installation may be caused by

1. Software mismatches (Dependency problem)
2. Differences in installation path.

This recipe introduces a method to confirm installation from the beginning. However, it is important to read the error message well before everything else. It is no exaggeration to say that half of all problems can be solved if the user understands the error messages.

See Also

When the installation has been completed successfully, read [Learning HARK](#)

## 3.2 Sound recording fails

### Problem

Often a system may not work well because the recording itself has not been performed properly. This section describes

1. A method to confirm that the recording has been performed properly, and
2. The usual reasons that sound recording is not performed properly and measures to correct these problems.

### Solution

Try to record after reading the recipe [Learning sound recording](#). It will be easier to confirm later if a user says something for sound recording. Next, confirm that the file has been recorded using software that can display waveforms, such as [Audacity](#) and [wavsurfer](#). When recording using more than three microphones, it is convenient to use software that accepts multiple channels. If the display shows that each waveform has been recorded by all channels to which microphones have been connected, the recording has been successfully completed. If there are almost no amplitudes or clipping, confirm that

**Each microphone is working properly** Connect each to a familiar PC and confirm that each can record sounds.

**Each microphone is connected properly** Confirm if each is properly connected. Unplug a microphone and plug in again.

**The microphone has been plugged in** Some types of microphones cannot access a sufficient sound volume without an external power source (called plug in power). Although some sound recording devices supply power, if a microphone requires plug in power and the device does not supply power, an external power supply is required. Confirm by consulting the manuals for both the microphone and the device.

### Discussion

Speech recognition systems often do not work properly because the sound itself was not recorded or not recorded properly. particular, for a system with a large number of microphones, it is important to confirm that each microphone can record sounds before operating the software.

### See Also

A detailed method of sound recording is described in [Learning sound recording](#). A detailed description of sound recording devices are described in Chapter 7 in the HARK document.

## 3.3 Sound source localization fails

### Problem

My sound source localization system does not work well.

### Solution

This recipe introduces the usual debugging procedures for sound source localization systems.

#### Confirm the recording

Make sure the system can record sound. See [Sound recording fails](#).

#### Offline localization

Try offline localization using recorded wave files. Walk around the microphone array while speaking and record the sound. This is your test file.

Replace the node `AudioStreamFromMic` with `AudioStreamFromWave` in your network for offline localization. When `DisplayLocalization` and `SourceTracker` are connected, the localization result can be visualized.

If this step fails, set the parameter `DEBUG` to `ON` of `LocalizeMUSIC` and check the `MUSIC` spectrum. This value should be larger in the presence than in the absence of sound. If not, the transfer function file may be wrong. If the spectrum seems successful, adjust the parameter `THRESH` of `SourceTracker` so that its value is bigger than in the non-sound area and smaller than in the sound area.

Other parameters of `LocalizeMUSIC` can also be adjusted:

1. Set `NUM_SOURCE` to the total number of speakers.  
For example, if there are up to two speakers, set `NUM_SOURCE` to 2.
2. Set `MIN_DEG` and `MAX_DEG`.

If localization results are obtained from the direction where the sound is not located, it may be caused by a reflection from the wall or by a noise source (e.g. fans of a PC). As a solution, it is possible to assume that the target signals do not come from these directions, and the localization result can be set such that the output is within the range of `MIN_DEG` and `MAX_DEG`.

For example, if no sound is expected to come from behind, then the localization target can be set to output results only from the front by setting `MIN_DEG` to -90 and `MAX_DEG` to 90.

#### Online localization

Next is to use the original network file that uses `AudioStreamFromMic`, and then execute the network. The `THRESH` parameter of `SourceTracker` may need to be tuned because the value of `MUSIC` spectrum depends on the distance and volume of the speaker. Try to tune `THRESH` within the 0.1 - 0.2 range. If there are errors in the localization result, try to increase `THRESH`. If there is no localization result besides speaking to the microphone, try to decrease `THRESH`.

#### Measuring Ambient Noise

If there is a difference between the ambient noise level of the environment where the transfer function of `LocalizeMUSIC` is measured and where the sound source localization is executed, it may cause the performance to deteriorate. For example, if there is an air conditioner in the direction near the sound source localization, the sound source localization result may output that of the air conditioner. There are two countermeasures to avoid this case:

1. Direction Filtering  
Connect the `SourceSelectorByDirection` node after the `SourceTracker` node to ignore a sound source localization result from a specific direction. Another option is to change the `MIN_DEG` and `MAX_DEG` parameters of `LocalizeMUSIC` to specify a direction that will not output a sound source localization result.

## 2. Creating a Noise Correlation Function

The localization that eliminates the effect of the noise is possible by recording the noise beforehand and passing it to `LocalizeMUSIC`. It is effective when the noise is much powerful compared to the sound. Refer to [Learning sound separation](#) for more details.

### Discussion

It may be appropriate to change parameters, depending on reverberations in the room and the volume of the speaker's voice. To increase the localization performance of the current system, it may be better to tune up in the actual location. Since `THRESH` is the most important parameter here, adjusting it only will be the first thing to try.

### See Also

If you are new to building a sound source localization system, refer to [Learning sound localization](#). The chapter [Sound source localization](#) includes some recipes for localization. If you want to know the detailed algorithm, see `LocalizeMUSIC` and `SourceTracker` in the `HARK` document.

## 3.4 Sound source separation fails

### Problem

A mixture of sounds from the microphone input cannot be separated. Upon listening to output, the sound cannot be considered as speech, and the distortion is terrible.

### Solution

Confirm the following when performing sound separation using GHDSS node.

**Confirm that the source localization has been successfully completed** Since the GHDSS module uses source localization results (number of sound sources) for inputs, the separation performance degrades if localization failed. Modify the network files so that the localization results are displayed and confirm whether the system localizes sounds successfully. For further information, see the recipe, [Sound source localization fails](#).

**Confirm that GHDSS separated the sounds properly** To determine whether the GHDSS has been performed properly, save a result of GHDSS using SaveWavePCM and confirm that separation was successful. If separation failed in GHDSS , see [Parameter tuning of sound source separation](#)

**Confirm that post-processing was performed properly** When PostFilter or HRLE are inserted just after separation processing, separation may fail due to improper parameters. Save the post-processed sound and confirm that the post-processing was successful. If the post-processing failed, see [Reducing the leak noise by post processing](#)

### Discussion

None.

### See Also

[Sound source localization fails](#)  
[Parameter tuning of sound source separation](#)  
[Reducing the leak noise by post processing](#)

## 3.5 Speech recognition fails

### Problem

I am making a speech recognition system with HARK but it does not recognize any speech.

### Solution

If you have not yet tried the recipes in Chapter 2, starting with this chapter may be easier for you. In this chapter, the user will learn about a speech recognition system with HARK, in the order of sound recording, sound source localization, sound source separation and speech recognition.

Next, an inspection method will be described if an original system is developed by the user does not work. Since a large number of elements are included in a speech recognition system, it is important to verify possible causes one by one. First, confirm that HARK was installed properly (Recipe [Installation fails](#)), that sound is recording properly (Recipe [Sound recording fails](#)), that sound source localization is working properly (Recipe [Sound source localization fails](#)), and that sound source separation is working properly (Recipe [Sound source separation fails](#)) in each recipe.

If you verify that the system works properly through this stage, then, speech recognition must be verified. We presume that Julius (<http://julius.sourceforge.jp/>), a large vocabulary continuous speech recognition engine, which has been modified for HARK, is used in this system. Three files are important for using Julius.

1. Acoustic model: A model indicating the relationships between features and phonemes of acoustic signals
2. Language model: A model of the language spoken by the user of the system.
3. Configuration file: File names of these two models

If the system does not work at all or Julius does not start, a wrong path may have been designated for the file. Thus, the configuration file should be checked, for details, see Recipe [Making a Julius configuration file\(jconf\)](#). To verify the acoustic model, see [Creating an acoustic model](#); to verify the language model, see [Creating a language model](#).

### Discussion

This solution is for the system which does not recognize sounds at all. If the system works properly but its success (=recognition) rate is low, the system must be tuned up. Tuning up a speech recognition system involves complicated problems of localization, separation, and recognition, among others.

For example, see parameter tuning of GHDSS (Recipe [Parameter tuning of sound source separation](#)) for separation and tuning of PostFilter (Recipe [Reduce the leak noise by post processing](#)). Also see the chapter 10, which discusses features used for recognition, and recipes for improving performance ( [Tuning parameters of sound source localization](#) and [Parameter tuning of sound source separation](#)).

### See Also

Recipes only for when the system shows no recognition are shown here

1. Each recipe in the Chapter [Something is wrong](#)
2. [Acoustic model](#) and [Language model](#).
3. [Making a Julius configuration file \(.jconf\)](#)
4. Julius Book

## 3.6 Making a debug node

### Problem

How to create a module to debug the system I created.

### Solution

Basically, printing a standard output is a way to debug your own system.

- `cout << message1 << endl;`
- `cerr << message2 << endl;`

Furthermore, when executing a created network file (called `nfile.n` here), use this command line, which is not from GUI of HARK-Designer,

- `./nfile.n > log.txt`  
The message (above `message1`) output by `cout` is saved in `log.txt`.
- `./nfile.n 2> log.txt`  
The message (above `message2`) output by `cerr` is saved in `log.txt`.

Some nodes have a parameter `DEBUG` such as `LocalizeMUSIC` . Messages are output only when `DEBUG` is set a `true`.

## 3.7 Checking a microphone connection

### Problem

The system does not work well. The microphone connections may be flawed.

### Solution

To confirm that the microphones are connected, it is necessary to examine both the microphone and sound recorder. Connect the microphone to another PC; if recording is successful, the sound recorder of the first PC is the cause of your system failure. Connect another microphone to the sound recorder; if recording is successful, the microphone is the cause of your system failure. Check each microphone and recorder stepwise. For details, see [Sound recording fails](#)

### Discussion

When recording is unsuccessful, it is important to identify the points of the cause. Look for it patiently.

### See Also

[Sound recording fails](#)

## Chapter 4

# Microphone Array

### 4.1 Selecting the number of microphones

#### Problem

Read this section when mounting microphones on your robot.

#### Solution

In principle, it is possible to separate a desired number of sound sources when the number of sound sources + 1 microphones are prepared. In actuality, the performance of a system will depend on the layout and operating environment of each individual microphones. It is rare to know the number of sound sources initially, so the optimal number of microphones must be determined by trial and error.

It is therefore necessary to select the minimum number of microphones required for sound source localization, sound source separation, separated sound recognition depending on the level of performance needed.

Theoretically, the optimal layout for recording from sound sources in all directions is an equally-spaced layout on the arc of a concentric circle. We presume here that the head of a robot is a perfect sphere; if not, it might result in less than optimal sound source localization and separation in the direction at which the head shape shows a discontinuous reflection. It is better to set a concentric circle in the head, at which continuous reflection occurs.

#### Discussion

In the demonstration of the three-speaker simultaneous utterance recognition, three sound sources are separated with eight microphones. The number of separable sound sources is thus below half the theoretical value, 7. The number of microphones may be increased to, for example, 16 to improve performance and separate a larger number of sound sources. However, over-close microphone intervals between microphones have little effect on performance, while increasing calculation costs.

#### See Also

None.

## 4.2 Selecting the layout of the microphone array

### Problem

Read this section when mounting microphones on your robot.

### Solution

The precondition for layout is that the relative positions between individual microphones do not vary. The appropriate layout for accuracy of localization and separation depends on the directions of sound sources. If a sound source is located in a specific, known direction, the microphones can be positioned close to that direction. It is better to place microphones at wide intervals and perpendicular to the normal vector of the specific direction. If sound sources are located in all directions, then the microphones should be positioned in a circular pattern. Since wider inter-microphone intervals are better for sound source separation, the microphones should be dispersed as far apart as possible.

A layout of microphones poor in sound source localization can result in poorer sound source separation. Therefore, the layout should be dependent on sound source localization.

If localization accuracy is not good, reconfigure the layout so that it is not in a shape in which acoustic reflection becomes discontinuous around microphone positions, and avoid such locations for positioning.

### Discussion

When the relative position between microphones varies, so will the impulse response of a microphone array. We presume here that the impulse responses of a microphone array are fixed in HARK.

### See Also

None.

## 4.3 Selecting types of microphones

### Problem

Read this section if you are unsure what type of microphone to use.

### Solution

We have used non-directional electric condenser microphones, which only cost several thousand yen each. It is not always necessary to use more expensive microphones. Microphones with a higher signal-to-noise ratio are preferable. It is better to choose wired with proper covering.

### Discussion

To record sounds with a sufficiently high signal-to-noise ratio, choose wired with proper covering and with plugs. Although this type of microphone is usually expensive, we have confirmed that this system works with microphones costing several thousand yen each. When wiring inside a robot, make sure that all wires are covered and that interference by other signal wires is suppressed, rather than using expensive microphones.

### See Also

None.

## 4.4 Installing a microphone array in a robot

### Problem

Read this section when wiring microphones into the robot.

### Solution

Shorten the length of the wires first before wiring the microphones. When wiring inside the robot, make sure that the microphone wires are not in parallel with other wiring such as power wires and signal wires for servos. For signal transmission, it is better to use differential and digital types.

Set the microphones so that they are in contact with the surface of the robot's housing. Make sure that the microphones are embedded in the housing, with only the tips visible from the outside of the robot.

### Discussion

The microphones are affected by reflections from the robot housing when they are isolated from the surface. This will cause the performance of sound source localization and sound source separation to deteriorate. Make sure that the microphones do not pick up the vibrations caused by the housing during robot operations. Use materials such as bushings for mounting the microphones to suppress vibrations.

### See Also

None.

## 4.5 Selecting a sampling rate

### Problem

Read this section to determine the sampling rate when entering acoustic signals from a device.

### Solution

If there is no particular reason, it is sufficient to use the initial 16kHz sampling rate. If that is not the case, use the lowest sampling rate within a range that has no aliasing.

It is necessary to set a sampling rate with a consideration that no aliasing occurs. The frequency that is a half the sampling rate is called the Nyquist frequency. Signals with frequency that exceeds Nyquist frequency are aliased during sampling. Therefore, it is advised to use the highest possible sampling rate to prevent aliasing in the input signals. The higher the sampling rate, the lower the possibility for aliasing to occur.

On the other hand, when high sampling rate is used, the amount of data to be processed increases, which also increases the calculation cost. Which means that the sampling rate should not be set more than what is necessary.

### Discussion

Speech energy reaches over 10kHz in bandwidth, with much of the energy present as low frequency components. Therefore, consideration of low frequency bands is often sufficient for most purposes. For example, for telephones, sampling ranges from around 500 Hz to 3,500 Hz , making the transmission of interpretable audio signals with bandwidths of up to around 5kHz [1] possible. For 16kHz sampling, frequency components  $\leq 8\text{kHz}$  can be sampled without alias, making it useful for speech recognition.

[1] Acoustic analysis of speech, by Ray D Kent and Charles Read, translation supervised by Takayuki Arai and Tsutomu Sugawara, Kaibundo, 2004.

### See Also

None.

## 4.6 Using an A/D converter unsupported by HARK

### Problem

Read this section if you wish to capture acoustic signals using devices other than the sound cards supported by ALSA (Advanced Linux Sound Architecture), the RASP series (System In Frontier, Inc.), and TD-BD-16ADUSB (Tokyo Electron Device), all of which are supported by HARK as standards.

### Solution

An A/D converter can be used by a corresponding node created by the user. We describe here a procedure for creating an `AudioStreamFromMic` node that supports, for example, `NewDevice`. The overall procedure consists of:

1. Creation of a class `NewDeviceRecorder` corresponding to the device and placing its source and header files into the `librecorder` directory in the HARK directory.
2. Rewriting `AudioStreamFromMic` so that the created class can be used.
3. Rewriting `Makefile.am`, `configure.in` to compile.

In (a), a class is created that takes data from the device and sends them to a buffer. This class is regarded as the successor to the `Recorder` class. Initialization prepares the device for use, followed by the `operator()` method, which removes data from the device.

In (b), processing is performed when “`NewDevice`” is designated as the option is described. The `NewDevice` is designated and initialized in the constructor, and the signals are set.

In (c), `Makefile.am` and `configure.in` are changed to correspond to the newly added file. Described below is a sample of `AudioStreamFromMic 2`, which supports a new device (`NewDevice`)

---

```
#include "BufferedNode.h"
#include "Buffer.h"
#include "Vector.h"
#include <climits>
#include <csignal>
#
include <NewDeviceRecorder.hpp> // Point1:
Read a required header file
using namespace std;
using namespace FD;
class AudioStreamFromMic2;
DECLARE_NODE( AudioStreamFromMic2);
/*Node
*
* @name AudioStreamFromMic2
* @category MyHARK
* @description This node captures an audio stream using microphones and outputs frames.
*
* @output_name AUDIO
* @output_type Matrix<float>
* @output_description Windowed wave form.
A row index is a channel, and a column index is time.
*
* @output_name NOT_EOF
* @output_type bool
* @output_description True if we haven't reach the end of file yet.
*
* @parameter_name LENGTH
```

```

* @parameter_type int
* @parameter_value 512
* @parameter_description The length of a frame in one channel (in samples).
*
* @parameter_name ADVANCE
* @parameter_type int
* @parameter_value 160
* @parameter_description The shift length between adjacent frames (in samples).
*
* @parameter_name CHANNEL_COUNT
* @parameter_type int
* @parameter_value 16
* @parameter_description The number of channels.
*
* @parameter_name SAMPLING_RATE
* @parameter_type int
* @parameter_value 16000
* @parameter_description Sampling rate (Hz).
*
*
@parameter_name DEVICETYPE // Point2-1:
Add the type of a device to be used
* @parameter_type string
* @parameter_value NewDevice
* @parameter_description Device type.
*
*
@parameter_name DEVICE // Point2-2:
Add the name of a device to be used
* @parameter_type string
* @parameter_value /dev/newdevice
* @parameter_description The name of device.
END*/
// Point3:
Describe processing to stop sound recording in the middle
void sigint_handler_newdevice(int s)
{Recorder* recorder = NewDeviceRecorder::
GetInstance();
recorder->Stop();
exit(0);
}
class AudioStreamFromMic2:
public BufferedNode {
int audioID;
int eofID;
int length;
int advance;
int channel_count;
int sampling_rate;
string device_type;
string device;
Recorder* recorder;
vector<short> buffer;
public:
AudioStreamFromMic2(string nodeName, ParameterSet params)
:
BufferedNode(nodeName, params), recorder(0)
{
audioID = addOutput("AUDIO");
eofID = addOutput("NOT_EOF");
length = dereference_cast<int> (parameters.get("LENGTH"));
advance = dereference_cast<int> (parameters.get("ADVANCE"));
channel_count = dereference_cast<int> (parameters.get("CHANNEL_COUNT"));
sampling_rate = dereference_cast<int> (parameters.get("SAMPLING_RATE"));
device_type = object_cast<String> (parameters.get("DEVICETYPE"));
device = object_cast<String> (parameters.get("DEVICE"));
// Point4:
Create a recorder class corresponding to the device type

```

```

if (device_type == "NewDevice")
{recorder = NewDeviceRecorder::
GetInstance();
recorder->Initialize(device.c_str(), channel_count, sampling_rate, length * 1024);} else {
throw new NodeException(NULL, string("Device type " + device_type + " is not supported."), __FILE__, __LINE__);}
inOrder = true;}
virtual void initialize()
{outputs[audioID].
lookAhead = outputs[eofID].
lookAhead = 1 + max(outputs[audioID].
lookAhead, outputs[eofID].
lookAhead);
this->BufferedNode::
initialize();}
virtual void stop()
{recorder->Stop();}
void calculate(int output_id, int count, Buffer &out)
{Buffer &audioBuffer = *(outputs[audioID].
buffer);
Buffer &eofBuffer = *(outputs[eofID].
buffer);
eofBuffer[count]
= TrueObject;
RCPtr<Matrix<float> > outputp(new Matrix<float> (channel_count, length));
audioBuffer[count]
= outputp;
Matrix<float>& output = *outputp;
if (count == 0)
{ //Done only the first time
recorder->Start();
buffer.resize(length * channel_count);
Recorder::
BUFFER_STATE state;
do {usleep(5000);
state = recorder->ReadBuffer(0, length, buffer.begin());} while (state != Recorder::
OK);
// original
convertVectorToMatrix(buffer, output, 0);} else { // Normal case (not at start of file)
if (advance < length)
{Matrix<float>& previous = object_cast<Matrix<float> > (
for (int c = 0;
c < length - advance;
c++)
{for (int r = 0;r < output.nrows();r++)
{output(r, c)= previous(r, c + advance);}} else {for (int c = 0;c < length - advance;c++)
{for (int r = 0;r < output.nrows();
r++)
{output(r, c)= 0;}}}
buffer.resize(advance * channel_count);
Recorder::
BUFFER_STATE state;
for (;)
{
state = recorder->ReadBuffer((count - 1)
* advance + length,
advance, buffer.begin());
if (state == Recorder::
OK)
{break;} else {usleep(5000);}
}
int first_output = length - advance;
convertVectorToMatrix(buffer, output, first_output);
}
bool is_clipping = false;
for (int i = 0;
i < buffer.size();
i++)
{

```

```

if (!is_clipping && checkClipping(buffer[i]))
{
is_clipping = true;
}
}
if (is_clipping)
{
cerr << "[" << count << "]"[" << getName()
<< "]" clipping" << endl;
}
}
protected:
void convertVectorToMatrix(const vector<short>& in, Matrix<float>& out,
int first_col)
{
for (int i = 0;
i < out.nrows();
i++)
{
for (int j = first_col;
j < out.ncols();
j++)
{
out(i, j)
= (float) in[i + (j - first_col)
* out.nrows()];
}
}
}
bool checkClipping(short x)
{
if (x >= SHRT_MAX ||
x <= SHRT_MIN)
{
return true;
} else {
return false;
}
}
};

```

---

The following is the outline of a source code of the class that was derived from the Recorder class, enabling the NewDevice to be used. We describe the process required to connect to the device with an initialize function and to read data from the device to the () operator. This source code (NewDeviceRecorder.cpp) is created in the librecorder Folder.

---

```

#include "NewDeviceRecorder.hpp"
using namespace boost;
NewDeviceRecorder* NewDeviceRecorder::
instance = 0;
// This function is executed in another thread, and
// records acoustic signals into circular buffer.
void NewDeviceRecorder::
operator()()
{
for(;;)
{
// wait during less than (read_buf_size/sampling_rate)
[ms]
usleep(sleep_time);
mutex::
scoped_lock lk(mutex_buffer);
if (state == PAUSE)
{
continue;
}
}
}

```

```

}
else if (state == STOP)
{
break;
}
else if (state == RECORDING)
{
lk.unlock();
// Point5:
Processing to read data from the device is described here.
read_buf = receive_data;
// Point6:
Forward cur_time for the time orresponding to the data read so far.
cur_time += timelength_of_read_data;
mutex::
scoped_lock lk(mutex_buffer);
buffer.insert(buffer.end(), read_buf.begin(), read_buf.begin()
+ buff_len);
lk.unlock();
}
}
}
int NewDeviceRecorder::
Initialize(const string& device_name, int chan_count, int samp_rate, size_t buf_size)
{
// Point7:
Processing to initialize variables and devices to be used is described.
new_device_open_function
}

```

---

### Discussion

The `AudioStreamFromMic` module performs only the processing required to read the contents of the buffer belonging to the `Recorder` class. Data exchange with devices are performed by each class (`ALSARecorder`, `ASIORecorder`, and `WSRecorder`) derived from the `Recorder` class. Therefore, a new device can be supported by implementing a class corresponding to these derived classes (`NewDeviceRecorder`).

### See Also

The details of constructing a node are described in Section 12.1, “How to create nodes?”. See the source code for reference in creating the `NewDeviceRecorder` class (for example: `ALSARecorder` class)

# Chapter 5

## Input Data Generation

### 5.1 Recording multichannel sound

#### Problem

To record a multichannel acoustic signal from a microphone array.

#### Solution

#### HARK-supported devices

Multichannel recording requires an audio device that supports synchronized multichannel input. HARK currently supports the following devices (for more details and connection procedures, see chapter 8 of the HARK document).

**ALSA** Audio devices that can be accessed via Advanced Linux Sound Architecture (ALSA),

**RASP** RASP series, System In Frontier, Inc.

**TDBD** TD-BD-16ADUSB, Tokyo Electron Device Ltd.

#### Two recording methods

There are two methods to record a sound in HARK. One is by creating a HARK network, and another is by using a support tool called `wios`. These two methods are explained more in details below:

#### Recording using a HARK network

HARK provided two nodes: `AudioStreamFromMic` for obtaining sound from a recording device(A/D converter), and `SaveRawPCM / SaveWavePCM` for saving the waveforms (See HARK Document for more details on the nodes). A recording network can be created by directly connecting these two nodes. (See Learning sound recording for details).

#### Recording using `wios`

HARK provided a support tool `wios` (Supported up to version 3.1, no longer supported from 3.2) for recording/playing sounds through ALSA, RASP, and TDBD. The best feature of `wios` is the ability to play and record a sound at the same time. In the current HARK localization and separation nodes, it is essential to measure beforehand the processes for transmitting sound from the sound source to each microphone (transfer function or impulse response). Because of that, being able to play-back audio signals for measurement while recording is necessary. In this section, only the procedure on how to record a sound is discussed. See the recipe [Recording impulse response](#) for details about measurement of impulse response.

After the HARK repository has been registered, `wios` can be installed by executing the command below: (See [HARK installation instructions](#) on how to register the repository).

```
sudo apt-get install wios
```

wios options has four categories. For a detailed description, see wios help by running wios without adding options.

**Mode options :**

Three modes: playing mode(-p), recording mode(-r), and synchronized-playing-and-recording mode(-s). Use -t to specify the duration.

**File options :**

File name for playing, (D/A) (-i); for recording (A/D) (-o).

Quantization bit rate (-e), sampling frequency(-f), number of channels(-c)

**Device options :**

Device type specification (-x) (ALSA:0, TDBD:1, RASP:2)

Device specification (-d). The meaning of this option depends on which type of device is specified. -d is the device name for ALSA (default: plughw:0,0), TDBD (default: /dev/sinhusb0), and the IP address for RASP (default: 192.168.33.24).

**Device-dependent options :**

Examples: ALSA: Buffer size; TDBD: Gain; RASP: Gain. See wios help for a complete list.

### Examples:

- Using a RASP device with an IP address of 192.168.1.1, ...
  1. Record sound with 8 channel for 3 seconds and save it to `output.wav`.  
`wios -r -x 2 -t 3 -c 8 -d 192.168.1.1 -o output.wav`
  2. Play the wave file `input.wav`  
`wios -p -x 2 -d 192.168.1.1 -i input.wav`
  3. Play `tsp.wav` and synchronously record the sound and save it to `response.wav`  
`wios -s -x 2 -d 192.168.1.1 -i tsp.wav -o response.wav`
- Using an ALSA-supported sound card installed in a computer, ...
  1. Record monaural sound for 10 seconds  
`wios -r -x 0 -t 10 -c 1 -o output.wav`
  2. Play `output.wav`  
`wios -p -x 0 -i output.wav`

### See Also

See [Learning sound recording](#) for a detailed description of sound recording using the HARK network. If recording fails, see [Sound recording fails](#) for troubleshooting.

For ALSA, RASP, and TDBD, see the chapter about devices in the HARK document. To use a device that is unsupported by HARK, see [Using an A/D converter unsupported by HARK](#).

See [Recording impulse response](#) for information about impulse response measurement.

## 5.2 Recording impulse response

### Problem

To measure impulse responses for sound source localization and sound source separation.

### Solution

#### Ingredients

A loudspeaker, a microphone array, an audio device that can simultaneously play and record a sound, and a signal including multiple TSPs are needed in the impulse response measurement. A wave file of a single TSP signal is installed in `/usr/bin/harktool3_utils` upon installation of `harktool` with a filename `16384.little_endian.wav`. Since this file includes only a single TSP signal, it is necessary to cut and paste to make multiple TSPs (e.g., 8 or 16 times) using waveform editing softwares such as `matlab` or `python`. Note that spaces should not be inserted between TSPs.

The number of TSP depends on the environment of the measurement. For example, 8-times TSP is enough in an environment with only a little noise. While 16-times TSP is recommended in an environment with a lot of noise, e.g a running air conditioner.

Similarly, a raw file `16384.little_endian.tsp`, which is a 32bit float wave data in a little-endian format is also installed in the same path. The `wavesurfer` software can be used to read the file. Below is the instruction on the installation and reading files using `wavesurfer`.

Installation of `wavesurfer`

```
\verb+sudo apt-get install wavesurfer+
```

Opening file using `wavesurfer`

```
wavesurfer /usr/bin/harktool3_utils/16384.little_endian.tsp
```

Then, set the configuration as shown in (Fig. 5.1)

#### Impulse Response Measurement Procedure

Impulse responses are measured in two steps: (1) playing and recording the TSP signal, and (2) calculating impulse responses from TSP signals.

1. Playing and recording the TSP signal

Playing multiple TSP signals and adding each signal reduces the background noise and vibrations. Files that includes 8-times TSP is named `tsp8.wav`.

Next is to use the HARK support tool `wios` for measurement. For example, to perform a synchronous recording-playback in an ALSA supported 8-channel multi-input device, execute the following command: (see [Recording multichannel sound](#) how to use `wios` )

```
wios -s -x 0 -i tsp.wav -c 8 -o r100_d000.wav
```

It is necessary to measure the impulse response of sounds coming from each direction. In about 1-2 meters of concentric circle from the center of the microphone array, move the speakers in order and with an equal angle while recording. For example, when the impulse response is measured in a 1 meter distance from the microphone array with 10 degrees interval, the following files will be generated:

```
r100_d000.wav  
r100_d010.wav  
...  
r100_d350.wav
```

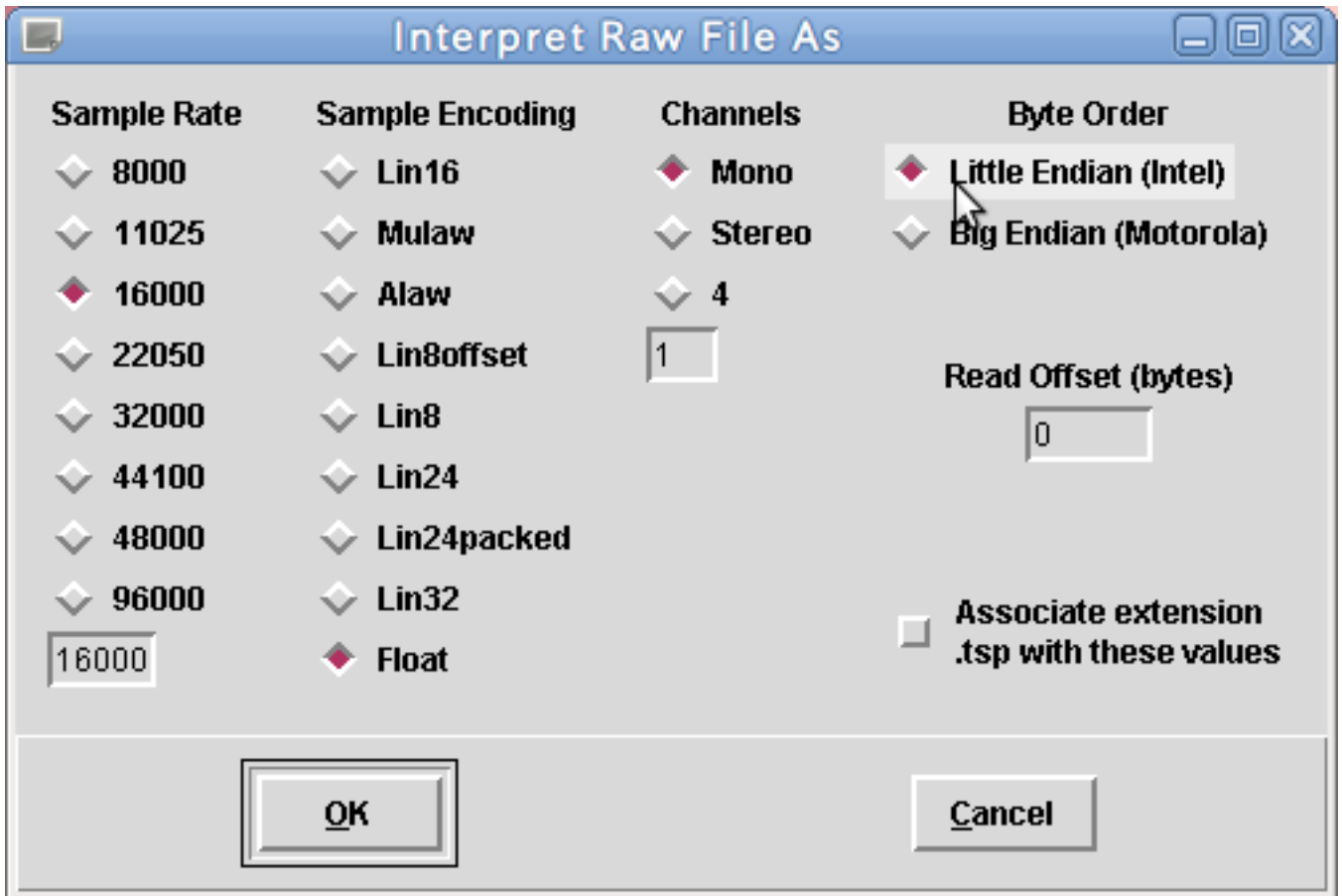

Figure 5.1: Configuration of wavesurfer needed to read raw files

2. Calculating impulse responses from TSP signals.

The impulse response is calculated by convolving the reverse TSP signal with the signal recorded in a way described above, and synchronously adding multiple playbacks to find the average value. harktool can be used in calculating impulse response. See the chapter on harktool in the HARK document for more details.

Discussion

Impulse response is an output of the system following the application of an impulse function to the system. Intuitively, the reverberation you hear upon clapping your hands in a room is a type of impulse response. The problem in actually measuring the “impulse response” is the need for a large amount of energy with a sufficient signal-to-noise ratio. To solve this problem, the impulse response is measured using a Time Stretched Pulse (TSP) signal, whose energy is stretched over time. Impulse response can be determined by recording the TSP and calculating the converse and inverse of the TSP [1,2]. The best interval between measurements is usually around 5 or 10 degrees, although it depends on the microphone array and on the shape and configuration of the room.

See Also

See [Recording multichannel sound](#) to determine how to use wios . See [HARK Installation Instructions](#) to determine and the section on harktool in the HARK document on the installation of HARK and the use of the harktool. We also provide an instruction video on the measurement of transfer function .

## References

- (1) Y. Suzuki, F. Asano, H.-Y. Kim, and Toshio Sone, "An optimum computer-generated pulse signal suitable for the measurement of very long impulse responses", J. Acoust. Soc. Am. Vol.97(2), pp.-1119-1123, 1995
- (2) Impulse response measurement using TSP (in Japanese) <http://tosa.mri.co.jp/sounddb/tsp/index.htm>

## 5.3 Synthesizing multichannel sound from impulse response

### Problem

To create an audio data through simulation and do an offline operation test.

### Solution

A multi-channel data can be synthesized if the waveform data of a sound source and the impulse response file are available.

Synthesizing is done by convolving the impulse response from the sound source to each microphone into the sound source data. Convolution stated here is a cyclic convolution method implemented at high speed using FFT. It is also possible to use Matlab. Below is the Matlab pseudocode for convolution:

```
x=wavread('SampleData1ch.wav');  
y1=conv(x,imp1);  
y2=conv(x,imp2);  
y3=conv(x,imp3);  
y4=conv(x,imp4);
```

Here it is assumed that SampleData1ch.wav is a 1-channel audio recorded in Microsoft RIFF format, with imp1, ..., imp4 indicating time-domain representations of impulse responses from the sound source to the microphone 1, ..., 4. Thus, y1,y2,y3 and y4 are the multi-channel synthesized sound being simulated.

It is important to confirm both the impulse responses and sampling frequency of the sound source data before synthesizing because the convolution of sounds with different sampling frequency is meaningless.

When synthesizing mixed sounds, it is advised to perform additive synthesis in the convoluted data.

### Discussion

The convolution of an original sound and an impulse response can simulate multiplicative noise. This multiplicative noise, such as transfer characteristics from the sound source to the microphone or the recording device, is modeled by the convolution to the clean signal. Therefore, this synthesis simulates multiplicative noise.

### See Also

To measure impulse response, see [Recording impulse response](#). To add noise, see [Adding noise](#).

## 5.4 Adding noise

### Problem

To add noise from a robot fan or motor for simulation.

### Solution

To apply the robot audition system to the real world, noise from the surrounding environment, the system itself, and/or a recording device must be considered. By recording these noises in advance and adding them to the original sounds, you can evaluate your system more realistically. Adding noise is simple; First, synthesize multichannel sounds using the recipe: Synthesizing multichannel sounds from impulse responses. Then, add the recorded noise. Matlab pseudo codes are shown below.

```
x=wavread('signal.wav');  
y=wavread('noise.wav');  
z=x+y;
```

where signal.wav denotes the original sound, noise.wav denotes the noise, and z is the simulated sound with additive noise.

### Discussion

Additive noise is noise that is added to the original sound, for example robot fan noise.

### See Also

To simulate multiplicative noise, see [Synthesizing multichannel sound from the impulse response](#).

## Chapter 6

# Acoustic and language models

### 6.1 Creating an acoustic model

#### Problem

This recipe discusses the creation of the acoustic model that is used in speech recognition. This is useful in improving the speech recognition performance after installing HARK in the robot.

#### Solution

An acoustic model is a statistical expression of the relationship between a phoneme and acoustic features and has a substantial impact in speech recognition. An acoustic model called Hidden Markov Model (HMM) is usually used.

When the layout of the microphones mounted in the robot is changed, or when the algorithm or parameter is changed during separation and speech enhancement, the properties of the acoustic features input into speech recognition may also change. Therefore, speech recognition can greatly improve by adapting an acoustic model to the new conditions or by creating a new acoustic model that meets these conditions.

The Hidden Markov Model Toolkit (HTK) is used to create the acoustic model for the speech recognition engine Julius used in HARK.

The next section describes the methods to construct the three acoustic models below:

1. Multi-condition training
2. Additional training
3. MLLR/MAP adaptation

Although there are various parameters in the actual acoustic model, a 3-state 16-mixture triphone will be used as an example. Many textbooks such as “HTK Book“, “IT Text Speech Recognition System“ etc. have been published which can serve as a reference to know more details about each parameter.

#### 6.1.1 Multi-condition Training

The fundamental flow of the creation of a typical triphone-based acoustic model is shown below.

1. Creation of training data
2. Extraction of acoustic features
3. Training of a monophone model
4. Training of a non-context-dependent triphone model

5. Status clustering
6. Training of a context-dependent triphone model

In addition to the clean audio signal, the recorded audio from the robot is also used during training in multi-condition training. The data used in speech recognition in HARK is a data acquired by using microphone array for recording and has undergone the sound source separation and speech enhancement process. For this reason, the data for training should also undergo sound source separation and speech enhancement.

However, since a large amount of audio data is needed in the acoustic model training, recording this type of data is not realistic. Because of this, the impulse response in the transmission between the sound source and the microphone array is measured beforehand, and then by convoluting this impulse response with the clean audio, the data recorded by using a microphone array can be created virtually. See 5.2 – 5.4 for more details on the concrete creation of data.

### Acoustic features extraction

The mel frequency cepstrum coefficient (MFCC) is often used for acoustic features. Although MFCC can be used, the Mel Scale Logarithmic Spectral coefficient (MSLS) is recommended for HARK. MSLS can be created easily from a wav file on a HARK network. MFCC can also be created on a HARK network in the same way. However, since MFCC is extracted in HTK, a similar tool HCopy is provided, making the number of parameters for MFCC extraction higher than in HARK. Regarding the usage of HCopy, refer to the HTKBook document. In any case, acoustic model is created by using HTK after feature extraction. See 10 for more details.

### Dictionary, MLF(Mater Label File) preparation

#### 1. Data revision:

Generally, even when using a distributed corpus, it is difficult to completely remove fluctuations in description and descriptive errors. Although these are difficult to notice beforehand, they should be revised as soon as they are found since such errors can degrade performance.

#### 2. Creation of words.mlf:

Filenames that are used as (virtual) labels to support the features, and the file “words.mlf“ which includes the utterance written per word is created. The header of “words.mlf“ file should be #!MLF!#. Each entry should have a labeled filename enclosed with “ “ which is defined in the first line. Then, the utterance included in the labeled filename is separated per word in each row. In addition, half-sized period “.“ should be added in the last row of each entry.

```
#!MLF!#
"/data/JNAS/pb/bm001a02.lab"
IQSHU:KANBAKARI
SP
NYU:YO:KUO
SP
SHUZAISHITA
.
"/data/JNAS/pb/bm001a03.lab"
TEREBIGE:MUYA
SP
PASOKONDE
SP
GE:MUO
```

```
SP
SHITE
SP
ASOBU
.
```

### 3. Creation of word dictionary:

A word dictionary which associates the phoneme strings with words is created. To put it simply, each phoneme string and the corresponding word is as follows:

```
AME a m e
TOQTE t o q t e
:
:
SILENCE sil
SP      sp
```

### 4. Creation of phoneme MLF(phones1.mlf):

Phoneme MLFs are created with a dictionary and word MLF. Use HLEd concretely.

```
% HLEd -d dic -i phones1.mlf phones1.led words.mlf
```

Rules are described in phones1.led. The rule allowing sp (short pose) is described in HTKBook.

```
EX
IS silB silE
```

The format of phoneme MLF is almost the same as that of word MLF except that the unit of lines is changed to phonemes from words. An example of phones1.mlf is shown below.

```
-----
#!MLF!#
"/data/JNAS/pb/bm001a02.lab"
silB
i
q
sh
u:
k
a
N
:
:
:
sh
u
z
a
i
sh
i
t
a
```

```

silE
.
"/data/JNAS/pb/bm001a03.lab"
:
:

```

### Preparation of the list train.scp for features file

Basically, this can be accomplished by creating a list of the feature quantity filenames in an full path (one filename per row). However, there are times when the feature quantity file contains abnormal values, and it is recommended to check the values first with HList, and only add files with correct values.

### Preparation of triphone

Although this operation can be done after the monophone training, it may be necessary to revise phones1.mlf depending on the check results. Thus in order to save time, this operation is performed here.

#### 1. Creation of **tri.mlf**:

First is to create a simple phoneme grouped by three.

```
% HLEd -i tmptri.mlf mktri.led phones1.mlf
```

An example of mktri.led is shown below. Phonemes described in mktri.led is removed from the context.

```

mktri.led
-----
WB sp
WB silB
WB silE
TC
-----

```

Parameters are reduced with short vowel contexts by identifying the anteroposterior long vowel contexts. An example of the created tri.mlf is shown below.

```

-----
#!MLF!#
"/data/JNAS/pb/bm001a02.lab"
silB
i+q
i-q+sh
q-sh+u: q-sh+u
sh-u:+k y-u:+k
u:-k+a u-k+a
k-a+N
a-N+b
N-b+a
b-a+k
a-k+a

```





## Monophone Training

```
% cd ../
% mkdir hmm1 hmm2 hmm3

Perform the training repeatedly for atleast three times. (hmm1 hmm2 hmm3) * hmm1

% HERest -C config.train -I phones1.mlf -t 250.0 150.0 1000.0 -T 1 \
-S train.scp -H hmm0/macros -H hmm0/hmmdefs -M hmm1

* hmm2

% HERest -C config.train -I phones1.mlf -t 250.0 150.0 1000.0 -T 1 \
-S train.scp -H hmm1/macros -H hmm1/hmmdefs -M hmm2

* hmm3

% HERest -C config.train -I phones1.mlf -t 250.0 150.0 1000.0 -T 1 \
-S train.scp -H hmm2/macros -H hmm2/hmmdefs -M hmm3
```

Although alignment settings should be readjusted at this point, it has been omitted here.

## Creation of Triphone

### 1. Creation of Triphone from Monophone:

```
% mkdir tri0
% HHEd -H hmm3/macro -H hmm3/hmmdefs -M tri0 mktri.hed monophones1.list
```

### 2. Initial training of triphone:

```
% mkdir tri1
% HERest -C config.train -I tri.mlf -t 250.0 150.0 1000.0 -T 1 -s stats \
-S train.scp -H tri0/macro -H tri0/hmmdefs -M tri1 triphones
```

Perform the training repeatedly for around 10 times.

## Clustering

### 1. Clustering of 2000 status:

```
% mkdir s2000
% mkdir s2000/tri-01-00
% HHEd -H tri10/macro -H tri10/hmmdefs -M s2000/tri-01-00 2000.hed \
triphones > log.s2000
```

Here, 2000.hed is described as follows. Stats on the first row is an output file obtained in 9.2. First, replace the value of thres to around 1000. Then set this value by trial and error so that the status number becomes 2000 in the execution log.

```

-----
RO 100.0 stats
TR 0
QS "L_Nasal" { N-*,n-*,m-* }
QS "R_Nasal" { *+N,*+n,*+m }
QS "L_Bilabial"
{ p-*,b-*,f-*,m-*,w-* }
QS "R_Bilabial"
{ *+p,*+b,*+f,*+m,*+w }
...
TR 2
TB thres "TC_N2_" {"N","*-N+*","N+*","*-N"}.
state[2]}
TB thres "TC_a2_" {"a","*-a+*","a+*","*-a"}.
state[2]}
...
TR 1
AU "physicalTri"
ST "Tree,thres"
-----

```

**QS** Question

**TB** The items written here are covered by clustering. In this example, only the same main phoneme with the same state is summarized.

**thres** Split threshold Control the final state number by changing the dividing threshold value properly (e.g. 1000 or 1200) (confirm log)

2. **Training:** Perform training after clustering.

```

% mkdir s2000/tri-01-01
% HERest -C config.train -I tri.mlf -t 250.0 150.0 1000.0 -T 1 \
-S train.scp -H s2000/tri-01-00/macro -H s2000/tri-01-00/hmmdefs \
-M s2000/tri-01-01 physicalTri

```

Repeat for more than three times

Increase of the number of mixtures

1. **Increasing the number of mixtures (example of 1 → 2mixtures):**

```

% cd s2000
% mkdir tri-02-00
% HHEd -H tri-01-03/macro -H tri-01-03/hmmdefs -M tri-02-00 \
tiedmix2.hed physicalTri

```

2. **Training:**

Perform training after increasing of the number of mixtures.

```

% mkdir tri-02-01
% HERest -C config.train -I tri.mlf -t 250.0 150.0 1000.0 -T 1 \
-S train.scp -H s2000/tri-02-00/macro -H s2000/tri-02-00/hmmdefs \
-M tri-02-01 physicalTri

```

Repeat for more than three times. Repeat these steps and increase the number of mixtures to around 16 sequentially. It is recommended to double the number of mixtures. (2 → 4 → 8 → 16)

### 6.1.2 Additional Training

In additional training, acoustic models are created by multi-condition training, or a clean acoustic model is used as a base acoustic model. Aside from those are basically the same as multi-condition learning.

For example, In the case of a 16-mixture triphone model based acoustic model, first, prepare an audio data for additional training with the same procedure as multi-condition training. Then, similar to the training after increasing the mixture count in multi-condition training (use HERest), perform the additional training to the audio data for additional training.

By additional training, even though the acoustic model originally used a different training data and underwent training, depending on the adaptive learning that used additional training data, the performance that is near to an additional training data that underwent multi-condition training from the beginning can be achieved.

Basically, to conform with the same method as using the multi-condition training, it is recommended to use a large amount of data for additional training. In case a large amount of data cannot be acquired, or if it is desired to shorten the calculation time of adaptive training, the MLLR/MAP adaptation in the next section is recommended.

### 6.1.3 MLLR/MAP Adaptation

In this method, it is the same with additional training in a sense that it uses a certain acoustic model. But, it is more of an adaptation method from a certain acoustic model to a target acoustic model by estimating the linear transformation matrix.

From HTK 3.3, the adaptation method changed from using HAdapt method to HERest method. Refer to the HTK book for more details.

See Also

[HTK Speech Recognition Toolkit](#). For acoustic models for Julius, see [source information of this document](#). For acoustic model construction for HTK, see [Acoustic model construction for HTK](#) For acoustic model construction for Sphinx, see [acoustic model construction tutorial for Sphinx developed by CMU](#), [acoustic model construction for Sphinx](#).

## 6.2 Creating a language model

### Problem

To describe a method for constructing language models for speech recognition.

### Solution

There are two types of language model, the large statistical language model, and the network grammar model, both can be used in Julius. (In the previous binary name, the former was called Julius, the latter was called Julian. But from ver 4, both were integrated to Julius). This chapter will focus more on the creation of statistical language models. Refer to the Julius website for more details on creating network grammar models.

### Creation of a dictionary for Julius

The dictionary is created based on the morphological analysis of the correct text in HTK format. `chasen` (tea bowl) is used for morphological analysis. After installing `chasen`, create `.chasenrc` in the home directory. Then, assign the directory that includes `grammar.cha` as “grammar file“. Then define the output format as:

```
(grammar file /usr/local/chasen-2.02/dic)
(output format "%m+%y+%h/%t/%f\n")
```

Prepare the correct text file and set the filename as “`seikai.txt`“. Then insert `<s>`, `</s>` at the beginning and end of each sentences since it will be used for language model creation.

Example of `seikai.txt` (words do not need to be separated)

```
<s> Twisted all reality towards themselves. </s>
<s> Gather information in New York for about a week. </s>
:
```

```
% chasen seikai.txt > seikai.keitaiso
```

See the contents of `text.keitaiso`; if any part of the morphological analysis is incorrect, revise it. Moreover, since the notation and reading of ”`he`” and ”`ha`” are different, alter the reading to ”`e`” and ”`wa`”, respectively. It may be necessary to normalize of morphemes and remove other unwanted parts. These steps are omitted here.

Example of `seikai.keitaiso`

```
<s>+<s>+17/0/0
+
+75/0/0
</s>+</s>+17/0/0
EOS++
<s>+<s>+17/0/0
```

Next, by executing the commands below:

```
% w2s.pl seikai.keitaiso > seikai-k.txt
```

The format of each row will be converted to half-space, the `<s>+<s>+17/0/0` above is replaced by `<s>`, and `</s>+</s>+17/0/0` above is replaced by `</s>`. Additionally, `EOS` is replaced by new line. With this, a morphologically analyzed corrected text can be created. This text will be used in the creation of the language model described below.

```
+  
+75/0/0 </s>
```

Lastly, use `seikai.keitaiso` to create the dictionary.

```
% dic.pl seikai.keitaiso kana2phone_rule.ipa |  
sort |  
uniq > HTKDIC  
% gzip HTKDIC
```

The `HTKDIC.gz` is the dictionary that will be used by Julius. use the option “-v” to use it.

Termx: Those that are included in morphological analysis, `chasen`, HTK format, `w2s.pl`, `dic.pl` and `kana2phone_rule.ipa - vocab2htkdic`

### Creation of language model for Julius

For creation of a language model, see “Speech recognition system” (Ohm sha). However, in order to create 2-gram and reversed 3-gram similar to the samples of `jconf`, using the CMU-Cambridge Toolkit alone is not sufficient, and the CMU-Cambridge Toolkit compatible “`palmkit`” should be used. Also, recently the reversed 3-gram became unnecessary in Julius, so there may be circumstances where `palmkit` is not needed.

Below is an example on how to use `palmkit`. Prepare the correct text, then set the file name to `seikai.txt`. It is a must for this file to complete the morphological analysis. (In other words, punctuation marks are expressed in words, and the words are separated by a space.) `<s>` and `</s>` are inserted at the beginning and end of the sentences, which is to remove the transition in the span of `<s>` and `</s>`.

Inserting `<s>` and `</s>` is required in `learn.css` file.

```
% text2wfreq < learn.txt > learn.wfreq  
% wfreq2vocab < learn.wfreq > learn.vocab  
% text2idngram -n 2 -vocab learn.vocab < learn.txt > learn.id2gram  
% text2idngram -vocab learn.vocab < learn.txt > learn.id3gram  
% reverseidngram learn.id3gram learn.revid3gram  
% idngram2lm -idngram learn.revid3gram -vocab learn.vocab -context learn.ccs  
% -arpa learn.rev3gram.arpa  
% idngram2lm -n 2 -idngram learn.id2gram -vocab learn.vocab -context learn.ccs  
% -arpa learn.2gram.arpa
```

This will create the 2-gram and reversed 3-gram, which will then be merged. By using Julius’ tool called `mkbingram`, the language model for Julius like the sample below can be created.

```
% mkbingram learn.2gram.arpa learn.rev3gram.arpa julius.bingram
```

### See Also

[This document is based from this webpage](#)

# Chapter 7

## HARK-Designer

### 7.1 Running the network from the command line

#### Problem

Although a network can be created and executed through the HARK-Designer's GUI, it is inconvenient to run the GUI everytime in order to execute the network. I want to execute the network file by using the command line, as well as to change the network parameters using command line arguments.

#### Solution

The target parameters and command line arguments should be set in the nodes within the network file in order to pass and process an argument from the command line.

Open HARK-Designer and edit the network file as shown below:

1. Open the node's property that includes the variable that will be passed as an argument in the MAIN subnetwork.
2. Set Type to `subnet_param` and Value to "ARG?" in the parameters of the variable that will substitute the command line argument. The ? is the index of the argument. The data type of the argument should also be specified if it is in `int` or `float` (i.e. "int:ARG1" or "float:ARG2").

Note that only the nodes in the MAIN subnetwork can pass a command line argument. To set the parameter of the nodes from other subnetwork, the parameter should first be set to `subnet_param` so that it can be seen in the MAIN subnetwork. The values can then be set through the MAIN subnetwork.

`batchflow` reads and executes the contents of the network file. Just type "batchflow" before the file name to execute the network.

```
$ batchflow foo.n 0.5 0.9
```

In this example, the input to ARG1 is 0.5, and ARG2 is 0.9 in `foo.n`, then it is executed by `batchflow`. This method is similar to both Windows and Ubuntu.

#### Discussion

HARK-Designer is the GUI for editing the network file, while the actual execution is done by `batchflow`.

All command line arguments are being handled as `string`. To pass an argument that is in `int` or `float` data type, Value should be set as "int :ARG1", "float :ARG1".

Passing command line arguments by this method that are `Object` type such as `Vector<int>` are not allowed in the current version of HARK .

See also

None.

## 7.2 Copying nodes from other network files

### Problem

I cannot copy and paste a node from other files.

### Solution

Often times there is a need to copy and paste a node that already contains preset settings from other files. HARK-Designer supports the normal method on how to cut, copy and paste which are described in the procedure below:

- 1) Click "File". Load the network file that contains the block to be copied.
- 2) Select the block to be copied, and click "Right click" -> "Copy "
- 3) "Right click" -> "Paste " at the copy destination

The following shortcuts can also be used:

- **Ctrl-c** : Copy
- **Ctrl-x** : Cut
- **Ctrl-v** : Paste

### 7.3 Making an iteration using HARK-Designer

#### Problem

I want a process to be performed a fixed number of repetition like in a “for loop.”

#### Solution

This can be done by using the `Iterate` subnetwork and `Iterator` node.

For example, if the localization result of `ConstantLocalization` is to be passed to `DisplayLocalization` 500 times, the network should be created as shown in Fig.7.1. Note that the `Iterate` node is at `New Node → Flow → Iterator`.

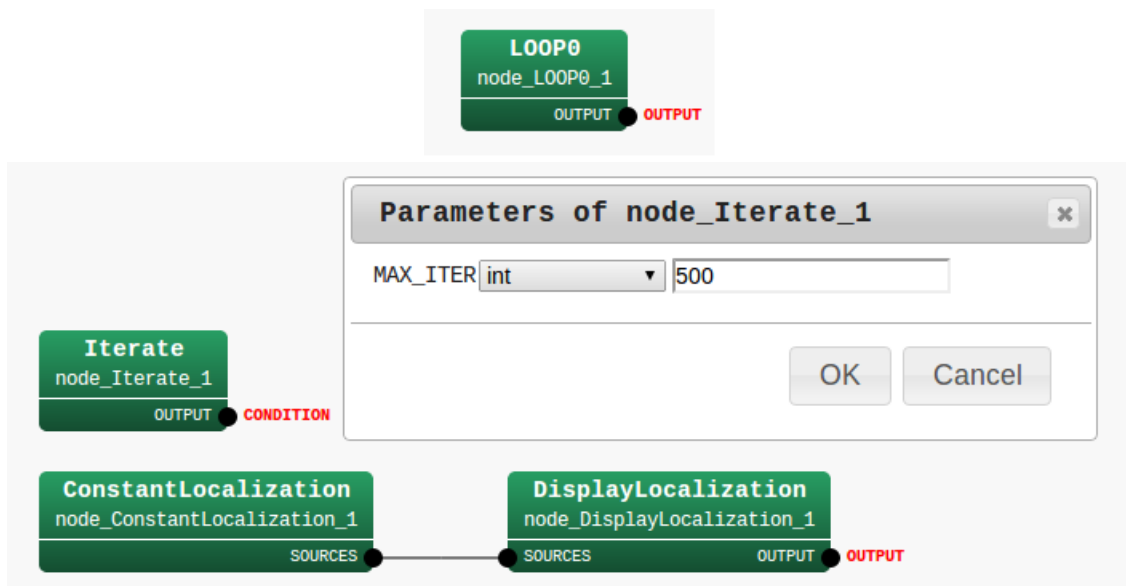

Figure 7.1: Sample network: The left panel is the `MAIN` subnetwork, and the right panel is the `Iterate` sub-network

Execute the network. The network is working properly if the fixed sound source localization result displays the frame number set in the `Iterate`.

#### Discussion

`Iterate` The loop count set in the `MAX_ITER` decrements every repetition. If the value is more than 0, the output is set to `true`, otherwise, it is set to `false`.

By setting this output in the `CONDITION` terminal, the process will only be performed by the number of repetition defined.

#### See Also

None.

# Chapter 8

## Sound source localization

### 8.1 Introduction

#### Problem

I wish to localize sound using a microphone array.

#### Solution

HARK provides not only sound source localization, but also tracking, visualization, saving, and loading localized results. This recipe introduces other recipes in this chapter. If this is the first time you are performing localization, read [Learning sound localization](#) and build a localization system. Then, debug the system using the recipe: [Checking if the sound source localization works successfully](#). For any problems, see recipes such as [Too many localization results / no localization results](#) or [The localization result is fragmented / Isolated sounds are connected](#). For problems connecting localization with separation, see [Ignoring the beginning of separated sound](#). To analyze localization results, save them to files using the recipe [Saving the localization results to a file](#)

To improve the localization performance, tune the parameters using the recipe [Tuning the parameters of sound source localization](#). If your situation includes multiple sound sources, tune the parameters using the recipe [Localizing multiple sounds](#). If you want to localize not only the azimuth but the elevation, see the recipe [Localizing the height or the distance of the source](#). If you want to use part of a microphone array, use the recipe [Use the part of microphone array](#).

#### Discussion

There are seven primary nodes for localization:

#### **Localization LocalizeMUSIC**

Main node. This outputs localization results from input signals.

#### **Generate constant localization ConstantLocalization**

Debugging node. This generates constant localization results.

#### **Tracking the localization SourceTracker**

This tracks the localization results and gives the same ID to the same source.

#### **Visualize the result DisplayLocalization**

Visualization node.

#### **Save and load the result SaveSourceLocation and LoadSourceLocation**

This node saves and loads the localization results to a file.

**Extend the result `SourceIntervalExtender`**

This node extends the localization results for sound separation.

See also

See the HARK document for the usage of each node. See `LocalizeMUSIC` in the HARK document for a theoretical description of localization.

## 8.2 Tuning parameters of sound source localization

### Problem

How should I adjust the parameters when sound source localization is suboptimal?

### Solution

The solution is given for each sound localization problem.

#### Q.1) Localization directions are indicated poorly messily or are not indicated at all.

When displaying a localization result in `DisplayLocalization`, the localization directions may not be indicated precisely messily in some cases. This is due to the use of a low power source of sound has been localized as a sound source. If no directions are shown When results are not indicated at all, it is because of the opposite reason.

##### A.1-1) **Change THRESH of SourceTracker**

This is the parameter that directly changes the expected threshold value of the direction of a sound source. It should be adjusted so that only the peak of the sound source is captured well.

##### A.1-2) **Make NUM\_SOURCE of LocalizeMUSIC equal to the number of target sounds**

This enhances the peak of the target sound direction with NULL space, so that the number of peaks to be enhanced changes according to the setting of `NUM_SOURCE` (number of sound sources). When this setting is wrong, the performance deteriorates, including localizing a peak in the direction of noise or no peak in the direction of the target (In actual localization, only the sharpness of the peaks is degraded, so they still can be used for localization.) If there is only one speaker, the performance will be improved by setting `NUM_SOURCE1`.

#### Q. 2) Only one peak appears even though there are plural sound sources

A.2-1) **Change MIN\_SRC\_INTERVAL in SourceTracker** when there are sound sources nearby (e.g. two sound sources only 10 degrees away from each other). It may be necessary to set the value of `MIN_SRC_INTERVAL` sufficiently small (less than 10 degrees in this example). When the set value is greater than the angle difference, the two sound sources are localized as one sound source.

A.2-2) **Make NUM\_SOURCE of LocalizeMUSIC equal to the number of the target sounds** Same as A.2-1). Note that if the volume is loud enough, and the sounds are far enough apart (more than 40 deg), localization is usually sufficient well even if the parameter is ill configured.

#### Q.3) Non-vocal sound is used

**LOWER\_BOUND\_FREQUENCY and UPPER\_BOUND\_FREQUENCY of LocalizeMUSIC**

Sound source localization is processed for each frequency bin designated for these two frequencies. Therefore, setting a frequency totally different from that of the target sound will result in a wider peak. Use frequencies that correspond to those of target sound sources.

#### Q.4) I can assume that the sound does NOT come from a certain range.

**MIN\_DEG and MAX\_DEG of LocalizeMUSIC**

The sound source localization is performed only for the range determined by designating these two values. When wishing to perform localization for 360 degrees, make sure to designate 180 degrees and -180 degrees.

### Discussion

The solutions are parameter tuning of sound source localization. However, if the reverberation of your room is significantly different from the one of which you record the transfer function, you need to re-measure the transfer function. See HARK web page for the transfer function measurement instruction video.

For tuning the sound source localization parameters, especially the ones of `SourceTracker` node, visualization of MUSIC spectrum is very helpful. Here we describe an example to visualize the MUSIC spectrum using `matplotlib`, which is a python module.

**Step 1: output MUSIC spectrum** If you run your network file that includes `LocalizeMUSIC` node with `DEBUG` property is `true`, you will see that the output to the console (`stdout`) includes the lines starts with `MUSIC spectrum`. These values called MUSIC spectrum contain information used by `SourceTracker` .

Since these values get higher if the sound comes from the corresponding direction at the corresponding time frame, you can see when and from which direction the sound is detected by checking the MUSIC spectrum.

An example of console output is following:

```
reading A matrix
done
0:  17.68 -130.00   0.95  27.71
MUSIC spectrum: 26.409233 26.342979 26.311218 26.389189 26.684574 26.641804 26.473591 26.429607 26
0:  17.68 -130.00   0.95  28.03
MUSIC spectrum: 26.710100 26.621223 26.543722 26.562099 26.749601 26.577915 26.392643 26.393244 26
```

**Step2: visualizing MUSIC spectrum** If you use `imshow` method in `matplotlib` module, you can easily show the music spectrum.

Assume that you saved the log file above as `log.txt` and the script below as `showMusic.py`.

```
#!/usr/bin/env python
import pylab
import sys

musicspec = [map(float, line.split()[2:]) for line in open(sys.argv[1])
              if "MUSIC spectrum" in line]
musicspec = pylab.array(musicspec).transpose()

pylab.imshow(musicspec, interpolation="nearest", aspect="auto")
pylab.colorbar()
pylab.ylabel("Direction of Arrival")
pylab.xlabel("Time [frame]")
pylab.show()
```

Then, you can see the visualized image of MUSIC spectrum with the following command:

```
$ python showMusic.py log.txt
```

See Also

See `LocalizeMUSIC` in the HARK document for a detailed description of the MUSIC algorithm and parameters.

## 8.3 Using part of a microphone array

### Problem

I wish to localize a sound source using only part of my microphone array.

### Solution

You may want to evaluate your microphone array by using only part of it, e.g., use only 4 channels of an 8 microphone array.

Use the `SELECTOR` parameter of `ChannelSelector` for this purpose. Set the type of `SELECTOR` as `Object`, and the indices of the microphone using `Vector<int>`.

Adjust the `SELECTOR` parameter of the `ChannelSelector` module. Designate a type of parameter in `Object` and designate only the channel numbers of the microphones to be used for sound source localization in `Vector<int>`. For example, if you want to use only channels 1 and 3 of a 4 channel microphone array, the parameter should be `<Vector<int> 0 2>`.

### Discussion

None.

### See Also

See `ChannelSelector` of the HARK document for a more detailed explanation.

## 8.4 Localizing multiple sounds

### Problem

Read this section when

- Localization performance is degraded by the simultaneous presence of multiple sounds, or
- The user wishes to know the values of the properties of the number of sound sources in the `LocalizeMUSIC` module.

### Solution

As a simplification, the number of sound sources that can be localized simultaneously is equal to or less than the number of microphones to be used. If the number of target sound sources to be localized is  $N$ , this value should be set at  $N$ . If  $M$  noises are heard continuously from a specific direction, then this value should be set at  $M + N$ .

### Discussion

Theoretically, the MUSIC method can localize sound sources whose number is equal to or less than the number of microphones. That is, when using eight microphones, the maximum number of sound source is eight. Experimentally, however, stable localization can be performed only for up to  $3 \sim 4$  sound sources.

## 8.5 Checking if sound source localization is successful

### Problem

Read this section if

- You wish to confirm that the `LocalizeMUSIC` module was successful in performing sound source localization, or
- When processing using localization results, such as sound source separation with the `GHDSS` module, does not perform well.

### Solution

Localize a voice and a sound from a speaker in a specific direction and confirm their localization by collating with localization results. To confirm localization results, use the `DisplayLocalization` module and `SaveSourceLocation` . To confirm the accuracy of localization, set `MIN_DEG` of `LocalizeMUSIC` to - 180 and `MAX_DEG` to 180 so that sounds from all directions can be localized. If a sound does not come from a specific direction, the localization results may become stable by restricting the direction of the sound source; i.e., by setting `MIN_DEG` and `MAX_DEG` appropriately.

### Discussion

To improve localization accuracy

1. Measure the transfer functions of the microphone array
2. Appropriately tune the `SourceTracker`
3. Set so that localization is not performed from an angle at which where there is not a sound source.

### See Also

- [How should I save localization results in files?](#)
- [How should I determine threshold values of SourceTracker ?](#)
- HARK document: `DisplayLocalization` module
- HARK document: `SaveSourceLocation` module

## 8.6 Too many localization results / no localization results

### Problem

Read this section if

- Localization with the `LocalizeMUSIC` node is not performed well.
- Despite the absence of sounds, sound sources are continuously localized from a specific direction.
- You wish to set an appropriate value for the `THRESH` property of the `SourceTracker` node.

### Solution

1. Execute the network file for which the `DEBUG` property of the `LocalizeMUSIC` node is set to `true`.
2. Watch the power values of a `MUSIC` spectrum when there are no sounds and when there are sounds such as clapping.
3. Set the power value to an intermediate between these two.

The power should be set slightly higher than the steady power in the presence of silence. For example, if the steady power is around  $25.5 - -25.8$ , set `THRESH` at `26`. In step 1, visualizing the time-direction `MUSIC` spectrum like a spectrogram facilitates the choice of threshold.

### Discussion

Since the values output by the `LocalizeMUSIC` node are dependent on the gains of the microphones and the surrounding environments, appropriate values should be set by trial and error, as above. The following trade-off relationship arises in the setting of `THRESH`: When `THRESH` is set at a small value, localization can be performed for small power sources, allowing localization of unexpected noises (e.g. footsteps). When `THRESH` is set at a high value, loud sounds are not localized, whereas greater power is needed to localize uttered sounds.

### See Also

- Check if the sound source has been localized successfully
- How should I determine `PAUSE_LENGTH` for `SourceTracker` ?
- HARK document: `LocalizeMUSIC` node
- HARK document: `SourceTracker` node

## 8.7 Localization results are fragmented / Isolated sounds are connected

### Problem

Read this section if

- Despite sounds being continuous, localization results are discontinuous.
- All acoustic localization results are output continuously.
- The user wishes to set an appropriate value for the PAUSE\_LENGTH property of the SourceTracker module.

### Solution

1. Connect the SourceTracker module to the DisplayLocalization module and display the localization results.
2. Read an appropriate sentence aloud, and see the localization results.
3. **Localization results break off:** Increase the value of PAUSE\_LENGTH.
4. **Localization results are too close:**

### Discussion

The purpose of the PAUSE\_LENGTH property is to recognize speech appropriately, even if the power of a MUSIC spectrum in the LocalizeMUSIC module localizes it as continuous speech. Since this is applicable only to human speech, such a sound can be used. If your purpose is to localize human speech, use the default value.

**PAUSE\_LENGTH units** PAUSE\_LENGTH is measured in milliseconds. Therefore, the maximum PAUSE\_LENGTH depends on the sampling frequencies of the AudioStreamFromMic and AudioStreamFromWave modules (SAMPLING\_RATE) and the step size (ADVANCE) of FFT. If all parameters are set at their default settings (sampling frequency, 16000Hz; step size, 160 pt), changing PAUSE\_LENGTH by 1 corresponds to changing it 1 msec.

### See Also

- How should I use SourceIntervalExtender ?
- HARK document: SourceTracker module

## 8.8 The beginning of the separated sound is ignored

### Problem

Read this section if

- The beginning part of the separated sound breaks off.
- The beginning silent section of the separated sound is too long.
- The user does not know how to use the `SourceIntervalExtender` module.

### Solution

Adjust as follows.

1. Create a network file that can save a separation result (see [How should I save separated sounds in files?](#)). In this case, sandwich the `SourceTracker` and `SourceIntervalExtender` modules between a localization module such as the `LocalizeMUSIC` module and a separation module such as `GHDSS` module.
2. Separate a sound and display or listen to the result.
3. **If the beginning part of the separated sound breaks off**, increase `PREROLL_LENGTH`
4. **If the beginning silent section of the separated sound is too long**, reduce `PREROLL_LENGTH`

### Discussion

At the time point sound source localization is first reported, 500 msec has already elapsed from the start of the utterance and the beginning part of the separated sound is lost, leading to a failure of speech recognition. The `SourceIntervalExtender` module is designed to solve this problem. Measure `PREROLL_LENGTH` to determine how far to trace back from the start of sound source localization and separation. If `PREROLL_LENGTH` is too low, the beginning part of a separated sound will be lost, affecting on speech recognition. If, however, `PREROLL_LENGTH` is too high, an utterance may be connected to the one before or after it, leading to recognition errors in some language models used for speech recognition.

**Unit of `PREROLL_LENGTH`** The unit of `PREROLL_LENGTH` corresponds to 1 time frame when performing a Fourier transform for a short time. Therefore, its correspondence to actual time depends on the sampling frequency (`SAMPLING_RATE`) designated for the `AudioStreamFromMic` and `AudioStreamFromWave` modules and the step size (`ADVANCE`) of FFT. If all are set at their default settings (sampling frequency, 16000Hz; step size, 160 pt), a change of `PREROLL_LENGTH` of 1 corresponds to a change of 10 msec.

### See Also

- [How should I determine `PAUSE\_LENGTH` of `SourceTracker` ?](#)
- HARK document: The `SourceIntervalExtender` module

## 8.9 Localizing the height or distance of a source

### Problem

Read this section if you wish to determine

- The height of a sound source, as well as its direction on a horizontal surface
- The distance to a sound source as well as the direction it is coming from.

### Solution

The current `LocalizeMUSIC` module estimates only the direction of sound on a horizontal surface. To also estimate the height of a sound source and its distance from a microphone array, the program of the module must be remodeled. Since the MUSIC algorithm itself does not assume angles on a horizontal surface, it may be expanded. However, transfer functions for each datum to be localized will be required. For example, to estimate the height of a sound source, a transfer function from the sound source is required when changing the horizontal direction and height. Moreover, the microphone array must be positioned to capture the required information. For example, for direction localization on a horizontal surface, the microphones should be positioned on a horizontal surface; for also estimating height, the microphones should be positioned on the surface of a sphere.

### Discussion

Since the MUSIC algorithm estimates source locations based on prior transfer functions, this algorithm can be used to estimate height by measuring a transfer function according to the information required. However, since the implementation in HARK is limited to determining the direction of a sound source on horizontal surfaces, appropriate modifications are required.

### See Also

- HARK document: `LocalizeMUSIC`

## 8.10 Saving the localization results to a file

### Problem

Read this section if

- You do not know how to save localization results in files.

### Solution

Connect the `SaveSourceLocation` module to a module that outputs localization results such as the `LocalizeMUSIC`, `ConstantLocalization` and `LoadSourceLocation` modules. Designate a name of a file where localization results are saved in the `FILENAME` parameter.

### Discussion

None.

### See Also

- HARK document: `SaveSourceLocation`

# Chapter 9

## Sound Source Separation

### 9.1 Introduction

#### Problem

I want to separate a mixture of sounds.

#### Solution

HARK provides a sound separation node `GHDSS` to separate a mixture of sounds recorded by a microphone array. Sound must be localized first, because `GHDSS` inputs the direction of the sound. See [Learning sound separation](#) to build a sound source separation system.

`GHDSS` requires a transfer function from the position of the sound to each microphone. Two types of transfer function can be used: (1) actual measurements using TSP (Time Stretched Pulse) and (2) calculations from the microphone configuration by simulation.

1. Transfer function from recording

Put the microphone in a room and record the TSP signal. This improves separation performance by providing an actual transfer function. See [Recording impulse response](#).

2. Transfer function from simulation

Instead of recording impulse responses, you can calculate the transfer function from the locations of each microphone (the file is called `MICARY-LocationFile`). See `harktool` in the HARK document, and [Sound source separation using only the microphone array layout](#) to determine how to make the `MICARY-LocationFile`

After determining the transfer function the parameters must be configured (see [Learning sound separation](#)).

To save the separated sound itself, see the recipe [Saving separated sounds to files](#). To improve the separation performance, see the recipe: [Tuning the parameters of sound source separation](#).

To use the system in a noisy environment, see the recipe [Reducing the leak noise by post processing](#).

If your target sound or microphone array moves, see the recipe [Separating the moving sound](#).

#### Discussion

`GHDSS` separates sound using a higher-order decorrelation and geometric constraints based on the sound. See `GHDSS` module in the HARK document for details.

#### See Also

The node descriptions in the HARK document and the materials in the HARK tutorial may be helpful.

## 9.2 Saving separated sounds to files

### Problem

Use this section when listening to separated sounds for checking or when saving a separated sound to a file for experiments.

### Solution

Use the `SaveRawPCM` or `SaveWavePCM` module. The output format of `SaveRawPCM` module is the Raw format of Integer with no headers. The output format of `SaveWavePCM` module is the wave format of Integer with a header. Saving methods differ according to the values to be saved.

#### 1. Saving real number signals (temporal waveforms)

When saving temporal waveforms, connect `SaveRawPCM` or `SaveWavePCM`, as shown in Fig. 9.1. If not connecting a module that performs spectral transforms, such as `MultiFFT`, set the `ADVANCE` parameter identical to the number of dimensions of the input object (`INPUT`).

#### 2. Saving complex signals (spectrum)

When saving spectra, connect `SaveRawPCM` or `SaveWavePCM` as shown in Fig. 9.2. Both must first be resynthesized to form temporal waveforms. Connect the `Synthesize` module and convert the spectra into temporal waveforms. Subsequently connect `SaveRawPCM` or `SaveWavePCM`, as shown above for real number signals. Here, the `ADVANCE` parameter must be same as that of the `Synthesize` module. Determine if the signals have been saved successfully by seeing if a separated sound file was generated at the time of execution.

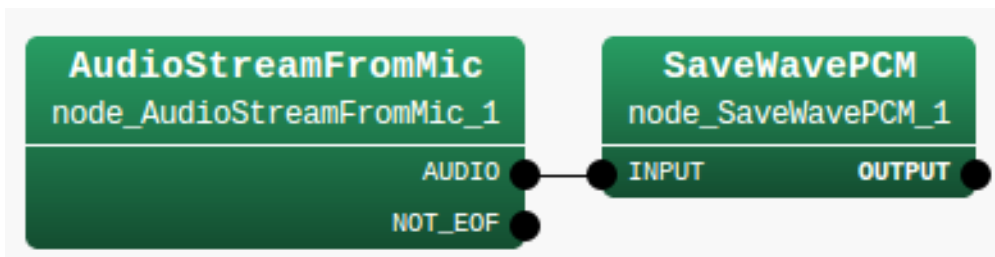

Figure 9.1: Connection example1

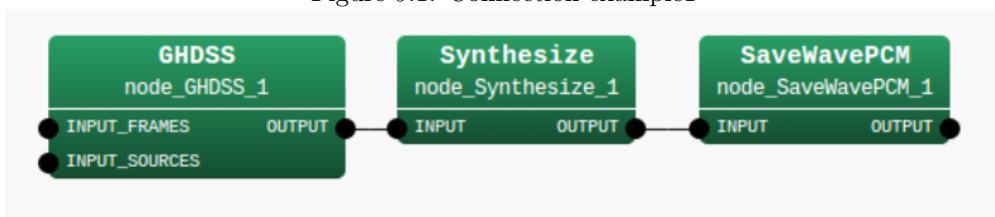

Figure 9.2: Connection example2

### Discussion

The `SaveRawPCM` and `SaveWavePCM` modules differ only in their headers. In general, the wave format has a header making it easier to deal with conventional software. Therefore, users should use the `SaveWavePCM` module.

### See Also

Module references for `Synthesize`, `SaveRawPCM` and `SaveWavePCM`.

## 9.3 Parameter tuning of sound source separation

### Problem

How should I adjust its parameters when sound source separation is suboptimal?

### Solution

This section describes the settings for GHDSS , the primary module for sound source separation.

#### 1) Settings dependent on pre-measured spatial transfer function

Since GHDSS separates using information on spatial transfer functions measured beforehand or calculated from microphone positions, its settings must be in accordance with those of the transfer functions concerned. Concretely, they correspond to the following set values.

- **LC\_CONST = FULL**

When transfer functions are measured properly, set this to **FULL**. Otherwise, **DIAG**.

#### 2) Determination of the curvature of non-linear constraints

In GHDSS , the coefficient **SS\_SCAL**, corresponding to the curvature (gradient at the origin) of a sigmoidal function, determines the performance. Increasing this curvature brings it closer to the linear constraint, whereas decreasing this curvature increases its non-linearity. Since too low a setting would result in a dull adaptation, its value should depend on the target environment.

#### 3) Initial separation matrix

You can specify the initial separation matrix by setting **INITW\_FILENAME**. An appropriate initial separation matrix reduces the convergence time for the separation. If you do not specify a file name, the initial matrix is constructed by the transfer function file and the localization result from **LocalizeMUSIC** .

#### 4) Step size calculation method

There are two types of step size calculation methods, **SS\_METHOD** for higher-order decorrelation, and **LC\_METHOD** for geometric constraints. The performance of both is improved by setting them to **ADAPTIVE** , unless the environment has been highly optimized. If you set **SS\_METHOD = LC\_METHOD = FIX**, **SS\_MYU = LC\_MYU = 0** and input an initial separation matrix by **INITW\_FILENAME**, separation may be realized by fixed beamformer. The details of each parameter are shown below:

##### 4-1) Step size calculation method for higher-order decorrelation : **SS\_METHOD**

###### 1. **FIX**

If **SS\_METHOD** is set at **FIX**, **SS\_MYU** will appear in the property window. You can input a value, e.g., 0.001, in **SS\_MYU**. A larger value reduces convergence time, while decreasing stability and accuracy. In contrast, a smaller value improves convergence stability and accuracy, while decreasing convergence time.

###### 2. **ADAPTIVE**

If **SS\_METHOD** is set as **ADAPTIVE**, the step size will be automatically optimized, improving the stability and accuracy of convergence.

###### 3. **LC\_MYU**

In this case, step size is defined by the **LC\_METHOD**.

##### 4-2) Step size calculation method for geometric constraints : **LC\_METHOD**

**1. FIX**

If you set LC\_METHOD as FIX, you can see LC\_MYU. The description is the same as that for SS\_METHOD.

**2. ADAPTIVE**

If LC\_METHOD is set to ADAPTIVE, the step size will be automatically optimized.

Discussion

See above description of solution

See Also

For details of the algorithms for sound source separation, see “Technical description of HARK (sound source separation)” in the HARK training session material.

## 9.4 Sound source separation using only the microphone array layout

### Problem

This section is for when wishing to separate a sound with the GHDSS module with a microphone coordinate, not with impulse responses.

### Solution

You obtain the transfer function in simulations with `harktool` . For details, see the description of the `harktool` .

### Discussion

None.

### See Also

`harktool`

## 9.5 Separating sounds with stationary noise

### Problem

To perform sound source separation while considering the effects of fixed noise such as the fan noise of a robot. Measurement of robot's noise source direction is required.

### Solution

Regarding the network, please see an example connection in the figure of `SourceSelectorByID`. Set the range excluding the direction of the stationary noise for the values of the parameters `MIN_DEG` and `MAX_DEG` of `LocalizeMUSIC`. Set 1 for the `MIN_ID` parameter value of `SourceTracker`. For the parameters of `ConstantLocalization`, set 0 for the `MIN_ID` and set the direction of the stationary noise source measured beforehand for the direction parameters. By connecting `SourceSelectorByID` to the sound source separation result such as output of `GHDSS`, the stationary noise can be filtered. To check whether or not it succeeded, examine the separated sound by using nodes which output the result such as `Synthesize`, `SaveRawPCM`. Separated sounds of the noise source are not output here.

### Discussion

None.

### See Also

`SourceSelectorByID`, `ConstantLocalization`

## 9.6 Reducing noise leakage by post processing

### Problem

Use this section when distortion is included in the separated sound and when wishing to improve automatic speech recognition by speech enhancement.

### Solution

This section describes the settings of nodes related to speech enhancement: `PostFilter` , `HRLE` , `WhiteNoiseAdder` and `MFMGeneration` .

#### 1) `PostFilter`

Depending on the situation, better recognition performance is obtained without `PostFilter` . It is necessary to set adequately the parameters of `PostFilter` for the given environment. Since the default parameters are determined based on the environment used by the HARK development team, there is no guarantee that they will be suited to the user's environment.

`PostFilter` contains many parameters, with many being interdependent. Therefore, it is extremely difficult to tune by hand operations. One solution is to use a combination optimization method. If a data set is available, apply an optimization method such as Generic Algorithm or Evolutional Strategy by using recognition rates and SNR for evaluations. Note that the system may learn parameters too specialized for the given environment.

In `PostFilter` , stationary noise, reverberation and noise leakage are dynamically estimated by the magnitude relationships of input signal power, with more precisely separated sounds obtained by subtraction. Under some conditions, performance may be degraded because the speech is distorted by such subtraction. Therefore, `PostFilter` is affected by estimations of stationary noise, reverberations and noise leakage. The influence of `PostFilter` can be minimized by setting the following parameters to 0.

- Leakage: `LEAK_FACTOR = 0`
- Reverberation: `REVERB_LEVEL = 0`
- Stationary noise: `LEAK_FACTOR = 0`

To increase the influence of `PostFilter` , bring these values closer to 1.

#### 2) `HRLE`

The number of parameters is much smaller in `HRLE` than in `PostFilter` . `HRLE` can enhance speech by calculating the spectral histograms of separated speech signals and detecting differences between noise and speech. Therefore, the design of the histogram has marked effects on speech enhancement performance. `HRLE` includes 5 parameters: `LX`, `TIME_CONSTANT`, `NUM_BIN`, `MIN_LEVEL`, and `STEP_LEVEL`. All these parameters, except for `LX`, are appropriate in the default setting. However, since `LX` defines the level of the surface between noise and speech, the best value depends on each acoustic environment. A higher `LX` can suppress high power noise but increase acoustic distortion. In contrast, a lower `LX` will reduce the distortion, but not suppress high power noise. Thus, set an appropriate `LX` depending on your environment.

#### 3) `WhiteNoiseAdder`

Adjust the value of `WN_LEVEL`. If it is too small, the distortion generated in the separated sound cannot be subtracted sufficiently. If it is too large, not only the distorted part but also the separated sound itself will be affected due to too much subtraction.

#### 4) `MFMGeneration`

Threshold values to mask features can be changed by changing the THRESHOLD value in the range from 0 to 1. All features are not masked when THRESHOLD is 0, indicating that some unreliable features are used for speech recognition. As THRESHOLD gets closer to 1, all features are masked, indicating that all features are not used. Both too high and too low values of THRESHOLD would degrade speech recognition.

#### Discussion

None.

#### See Also

["The separation cannot be performed properly. What should I do?"](#)

## 9.7 Separating a moving sound.

### Problem

Use this section if you do not know how to set `UPDATE_METHOD_TF_CONJ` and `UPDATE_METHOD_W` as properties of `GHSS` .

### Solution

If you do not understand well, use the default value. When changing it, you must determine if you are focusing on the sound source itself (`ID`) or the direction (`POS`). In particular, when a sound source moves or a robot's body moves, separation results change under conditions in which good separation traceability is needed. When focusing on `ID`, reuse the `ID` from an earlier step as a geometric constraint and separation matrix value. Therefore, when a sound source moves fast, those values will become inappropriate and separation will be unsuccessful. In contrast, when a sound source does not move much, the separation accuracy will continue to improve during reuse. When focusing on `POS`, the characteristics are reversed compared with `ID`. A focus on `POS` is suited for when a sound source moves at high speed. When the interval between movements is large, a database is used for values of a constraint condition, and the separation matrix or system is initialized. An ideal way is to apply these constraints to each sound source dynamically. For details, see the description of the `GHSS` module.

1. `UPDATE_METHOD_TF_CONJ`
2. `UPDATE_METHOD_W`

### Discussion

None.

### See Also

`GHSS`

# Chapter 10

## Feature Extraction

### 10.1 Introduction

#### Problem

Read this section to learn about the features available for speech recognition.

#### Solution

The features used for common speech recognition include:

1. LPC (Linear Predictive Coding: Linear prediction) coefficient
2. PARCOR (PARcial CORelated: Partial autocorrelation) coefficient
3. MFCC (Mel-Frequency Cepstrum Coefficient)
4. MSLS (Mel-Scale Log Spectrum)

HARK supports only MFCC and MSLS. For speech recognition using an acoustic model distributed on the web, use MFCC. For speech recognition based on missing feature theory, MSLS is better than MFCC.

#### Discussion

The LPC coefficient is a parameter of a model of a spectrum envelope. It is based on the value at time of  $t$  in the stationary process  $x_t$  being correlated with that of a recent sample. Figure 10.1 shows how to obtain the LPC coefficient. The LPC coefficient is a prediction coefficient ( $a_m$ ), in which the mean square error of the value ( $\hat{x}_t$ ) predicted from that of  $M$  input signals in the past and the value  $x_t$  of actual input signals are minimal. Since this LPC yields a comparatively precise speech model, it has been used widely for speech analysis-synthesis. However, a model based on LPC has a high coefficient of sensitivity and may become unstable due to a slight error in this coefficient. Therefore, speech analysis-synthesis is performed in the form of PARCOR.

PARCOR is a correlation coefficient of prediction errors of  $x_t$  (forward) predicted from  $x_{t-(m-1)}, \dots, x_{t-1}$  and  $x_{t-m}$  (backward). Figure 10.2 shows how to derive this PARCOR. In principle, a model based on this PARCOR is stable [1].

MFCC is a cepstrum parameter and is derived with filter banks placed at even intervals on a Mel frequency axis[1]. Figure 10.3 shows its process of derivation.

MSLS is derived by a filter bank analysis similar to that of MFCC, without performing the reverse discrete cosine transformation, the final step of MFCC extraction processing, and is a feature remaining in the frequency domain. When the noise at a specific frequency is mixed with acoustic signals, specific features including the frequency are affected in MSLS. For MFCC, however, the influence of noise spreads and many

features are affected. Therefore, in general, MSLS performs well when combining the missing feature theory for speech recognition.

[1] Hijiri Imai, sound signal processing, Morikita Shuppan Co., Ltd., 1996.

[2] Kiyohiro Shikano et al., IT Text speech recognition system, Ohmsha Co., Ltd., 2001.

See Also

MFCCEXtraction and MSLSEXtraction in HARK Document.

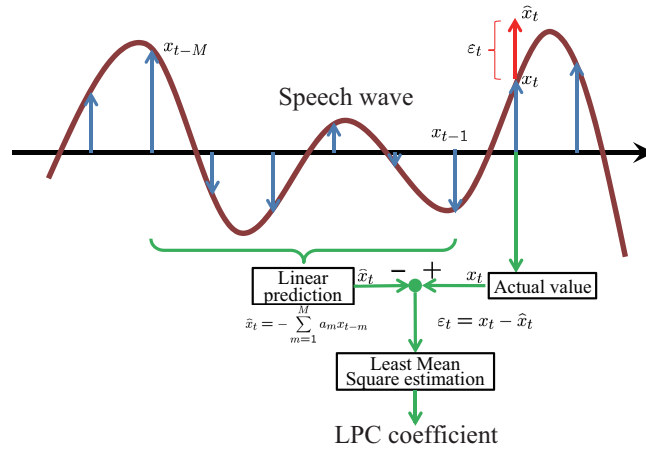

Figure 10.1: LPC coefficients

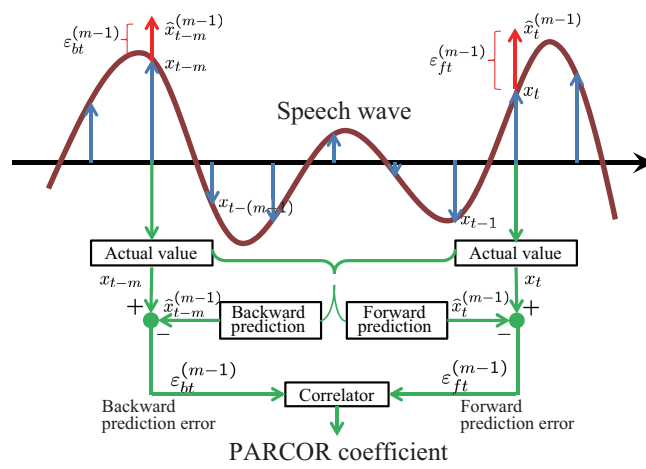

Figure 10.2: PARCOR coefficients

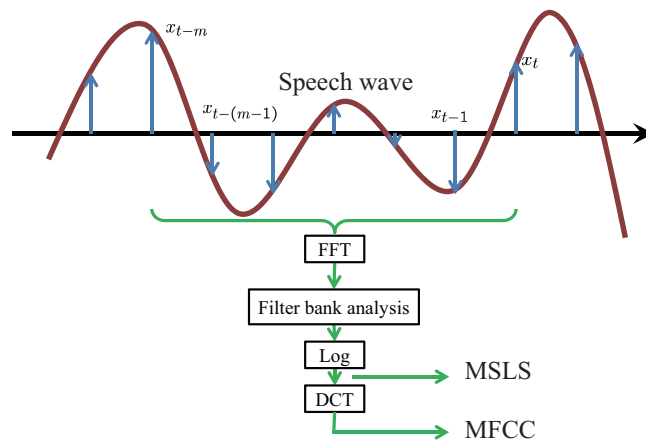

Figure 10.3: MFCC and MSLS

## 10.2 Selecting the threshold for Missing Feature Mask

### Problem

Read this section if you do not know how to set parameters of the MFMGeneration module.

### Solution

MFMGeneration includes the parameter THRESHOLD, which affects the performance of speech recognition. If the threshold value is set to 0.0, speech recognition will not be based on the missing feature theory. If it is set to 1.0, all features are covered with masks and therefore recognition is performed without any features. A suitable value is obtained experimentally through actual recognition, by changing threshold values in increments of 0.1.

### Discussion

MFMGeneration is expressed by the following equation. Reliability is threshold-processed in THRESHOLD, a mask that uses the two values of 0.0 (unreliable) and 1.0 (reliable) (hard mask).

$$m(f, p) = \begin{cases} 1.0, & r(p) > THRESHOLD \\ 0.0, & r(p) \leq THRESHOLD \end{cases}$$

where  $f$ ,  $p$ ,  $m(f, p)$ , and  $r(p)$  represent the frame, dimension, mask, and reliability of a feature, respectively.

### See Also

MFMGeneration in HARK Document

## 10.3 Saving features to files

### Problem

Read this section if you wish to save features extracted with HARK.

### Solution

Use `SaveFeatures` or `SaveHTKFeatures` module to save features. The `SaveFeatures` module saves features in float binary format, whereas the `SaveHTKFeatures` module saves features in HTK format. Figure 10.4 shows a network example, in which features are saved. Here, features are extracted and saved from a 1 channel audio signal read from the `AudioStreamFromMic` module. Features are saved by assuming the extracted features as inputs of the `SaveFeatures` module.

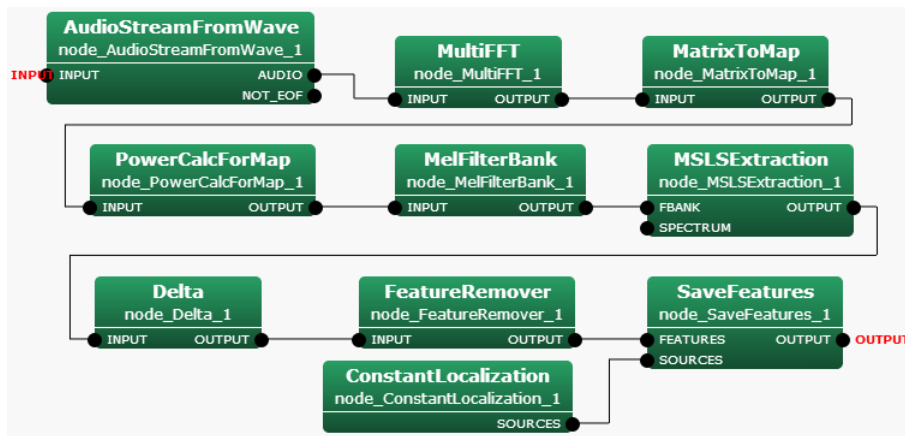

Figure 10.4: Sample network for saving features

### Discussion

The format used in the `SaveFeatures` module is 32 bit float and little endian, and the format used in the `SaveHTKFeatures` modules is HTK. The HTK format is better for training an acoustic model using HTK.

### See Also

`SaveFeatures` and `SaveHTKFeatures` modules and file format in HARK Document

# Chapter 11

## Speech Recognition

### 11.1 Making a Julius configuration file (.jconf)

#### Problem

Read this section if you do not know how to make a Julius configuration file (.jconf file) and what options should be set.

#### Solution

Julius includes many optional parameters that can be set by the user. It is complicated to designate options in Julius every time using command lines. A series of optional parameters can be set in a text file, thus simplifying option inputs in Julius. This text file is called a .jconf file. The options used in Julius are summarized in [http://julius.sourceforge.jp/juliusbook/ja/desc\\_option.html](http://julius.sourceforge.jp/juliusbook/ja/desc_option.html). All options can be described in text in a .jconf file. Important reminders when connecting Julius to `SpeechRecognitionClient` (or `SpeechRecognitionSMNClient`) are summarized. The minimum setting items are

- `-notypecheck`
- `-plugindir /usr/local/lib/julius_plugin`
- `-input mfcnet`
- `-gprune add_mask_to_safe`
- `-gram grammar`
- `-h hmmdefs`
- `-hlist allTriphones`

`-notypecheck` is an essential option. HARK uses an expanded acoustic parameter structure and is not supported by type check of the Julius default. Therefore, it is essential to add `-notypecheck`. When omitting this option, Julius detects a type error in the type check of features and does not recognize sounds.

For `-plugindir`, designate the path in which function enhancement plug-in files such as `mfcnet` are saved. This path must be designated before `-input mfcnet` and `-gprune add masks`. All enhancement plugs in files present in the plug-in path are read. For Windows OS, this option must be set even when the input option is not `mfcnet`. If `mfcnet` is disabled, the directory name can be arbitrary.

`-input mfcnet` is an option to recognize features received from `SpeechRecognitionClient` (or `SpeechRecognitionSMNClient`). Designate this option to support missing feature masks. Select the Gaussian pruning algorithm to support `-gprune`. Since calculations are performed while supporting the missing feature masks, the option name is different from that for normal Julius. Select from `{add_mask_to_safe || add_mask_to_heu`

`||add_mask_to_beam ||add_mask_to_none}` , which correspond to `{safe ||heuristic ||beam||none}` of normal Julius, respectively.

In addition, it is necessary to designate a language model and an acoustic model, the same as for normal speech recognition. Designate a grammar file in `-gram`, a definition file in `-h HMM` and an HMMList file in `-hlist`.

# Chapter 12

## Others

### 12.1 Selecting window length and shift length

#### Problem

Read this section to determine optimal window and shift lengths for analyses.

#### Solution

Length is the window length of speech for analysis, generally 20-40 ms. If the sampling frequency is  $f_s$  Hz,  $\text{length} = f_s/1000 * x$ , with  $x$  being 20-40 ms. Advance is an analysis frame shift length, which generally overlaps 1/2-1/3 of the preceding and following frames. When performing speech recognition, it is necessary to use the same Length and Advance for acoustic model creation.

#### Discussion

When analyzing speech, the range in which signals can be assumed to be weakly stationary is 20-40 ms; therefore, this section describes settings yielding these lengths. Shift length is determined as the execution width of a window. Concretely, determine the head of a rectangular window with energy equivalent to that of a window function. This window length is not utilized for frame processing of the same sample redundantly when analyzing continuous frames, making frame processing possible without discarding samples. Since the energy of window functions for speech analyses is about 1/3-1/2 of the rectangular window length, the amount of frame shift should be within this range. Although 1/3 is a conservative setting and may cause redundant frame processing of the same sample, few samples are discarded. Although samples may be discarded at settings of 1/2, depending on window functions, redundant frame processing does not occur. However, when using a rectangular window for analysis, the shift length must be equal to the analysis frame length. For triangular windows, the frame shift amount is 1/2.

## 12.2 Selecting the window function for **MultiFFT**

### Problem

Read this section to determine how to choose a window for MultiFFT .

### Solution

(three kinds: HUMMING, CONJ and RECTANGLE) For speech analysis, choose HUMMING. For other signals, choose an appropriate window for spectral analysis of signals.

## 12.3 Using PreEmphasis

### Problem

Read this section if you do not know whether to use the time domain or frequency domain for PreEmphasis .

### Solution

The necessity and effects of PreEmphasis for general speech recognition have been described in various books and papers. PreEmphasis can be used in both a time and a frequency domain. However, it is better to choose a domain while considering the data used for acoustic model training.

# Chapter 13

## Advanced recipes

### 13.1 Creating a node

#### Problem

I wish to create a node in HARK by myself but do not understand how to do so using only the material from a HARK training session.

#### Solution

To create a new node, it is necessary to install HARK by compiling a source, not by a debian package. To install from a source compilation, see “Installation of HARK” in the HARK training session material. When it is ready, describe the source of the node to be created. To learn how to make a basic node, consult the following items included in “Creation of a node” in the HARK training session material:

- Basic form of cc file (source file)
- Description with examples (ChannelSelector )
- Addition of parameter
- Rewriting method of Makefile.am

This section further describes the following items showing the actual creation of nodes such as `PublisherInt.cc` and `SubscriberInt.cc`

- Addition of input
- Addition of output
- Buffer (Lookback Lookforward)
- Input-output of each type
- Switching the number of inputs from static to configurable

#### Creation of PublisherInt.cc

First, create `PublisherInt.cc`, which reads integers as a parameter and discharges them without change. (note: the `hark_test` directory is assumed as a package.) Cut and paste the following source code to `{$PACKAGE}/hark_test/src/PublisherInt.cc`.



```

DECLARE_NODE(PublisherInt);
/*Node
 *
 * @name PublisherInt
 * @category HARK_TEST
 * @description This block outputs the same integer as PARAM1.
 *
 * @output_name OUTPUT1
 * @output_type int
 * @output_description This output the same integer as PARAM1.
 *
 * @parameter_name PARAM1
 * @parameter_type int
 * @parameter_value 123
 * @parameter_description Setting for OUTPUT1
 *
 END*/

```

In `DECLARE_NODE`, make sure that the `PublisherInt` class is defined as one node (an error will occur if it is not the same as the class name). `@name` seen in the comment out below is the setting for the declared node on GUI of HARK-Designer. It is not a comment, so make sure to set it. Four values are must be set: 1) the main body of the node, 2) the node inputs, 3) the node outputs, and 4) the node internal parameters. Other than the setting of 1), multiple values can be used (the setting method for multiple values are described later). The following are the concrete set values.

- Setting of the main body of the node
  - `@name`: Node name indicated on HARK (should be the same as the class name)
  - `@category`: Setting of the category to which the node belongs on GUI of HARK-Designer.
  - `@description`: Description of the node (can be omitted)
- Setting of node inputs
  - `@input_name`: Name of input indicated in the node
  - `@input_type`: Type of input variable
  - `@input_description`: Description of the input variable (can be omitted)
- Setting of node outputs
  - `@output_name`: Name of output indicated in the node
  - `@output_type`: Type of output variable
  - `@output_description`: Description of the output variable (can be omitted)
- Setting of internal parameter of the node
  - `@parameter_name`: Name of the parameter indicated in the node (indicated in a window when placing the mouse over it)
  - `@parameter_type`: Type of parameter
  - `@parameter_value`: Initial value of the parameter (can be changed in the source)
  - `@parameter_description`: Description of the parameter (can be omitted).

This source has one output and one internal parameter, and therefore they are displayed as Fig. 13.1 in HARK-Designer.

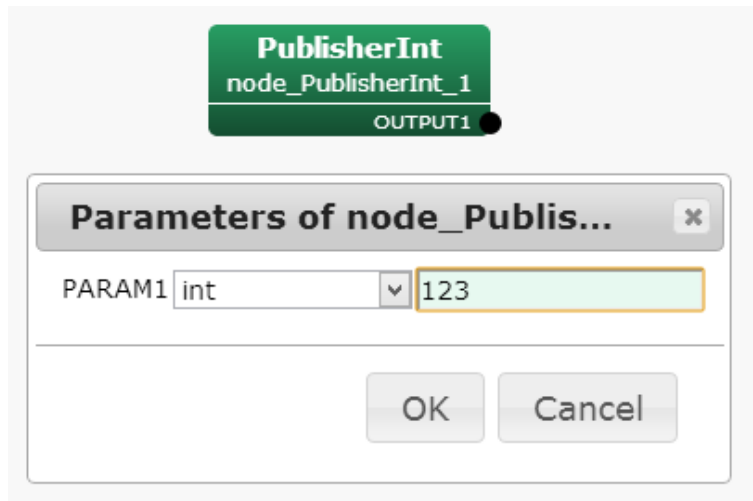

Figure 13.1: PublisherInt node

```
class PublisherInt : public BufferedNode {
    int output1ID;
    int output1;
    int param1;
};
```

Define the `PublisherInt` class that inherits the `BufferedNode` class, with the latter defined in HARK . `outputID` is an integer that stores an ID of an output port. The pointer to be passed to the output port is obtained based on this ID.

```
public: PublisherInt(string nodeName, ParameterSet params) : BufferedNode(nodeName, params)
{
    output1ID = addOutput("OUTPUT1");
    output1 = 0;
    param1 = dereference_cast<int>(parameters.get("PARAM1"));
    inOrder = true;
}
```

The constructor that inherits the `BufferedNode` class. `nodeName` (the class object name in the network files of HARK ) and `params` (an initializer of the variable `parameters` contained within the `Node` class and with internal parameters defined for some) are used as arguments.

`output1ID = addOutput("OUTPUT1");` becomes a row that stores the ID of `OUTPUT1` set in the HARK-Designer GUI in `output1ID` defined in the class.

`param1 = dereference_cast<int>(parameters.get("PARAM1"));` is the internal parameter set in the HARK-Designer GUI cast into `int` type. `@parameter_types` include `int` type, `float` type, `bool` type and `string` type, with others called `Objects`. (`string` type is called an `Object` and is cast into `string` .) Examples are shown below.

- `int` type (`int param;`)  
`param = dereference_cast<int>(parameters.get("PARAM"))`
- `float` type (`float param;`)  
`param = dereference_cast<float>(parameters.get("PARAM"))`
- `bool` type (`bool param;`)  
`param = dereference_cast<bool>(parameters.get("PARAM"))`
- `string` type (`string param;`)  
`param = object_cast<String>(parameters.get("PARAM"));`

- Vector type (`Vector<int> param;`)  
`param = object_cast<Vector<int>> >(parameters.get("PARAM"));`

`String` is not `std::string` and `Vector` is not `std::vector` because these types are special types for inputs and outputs of HARK . Errors occur if information is not transferred in these types. When setting `inOrder = true;`, `count` value increases by one every time `calculate` is performed (details below). In further describing the source,

```
void calculate(int output_id, int count, Buffer &out)
{
    // Main loop routine starts here.
    output1 = param1;
    cout << "Published : [" << count << " , " << output1 << "]" << endl;
    (*(outputs[output1ID].buffer))[count] = ObjectRef(Int::alloc(output1));
    // Main loop routine ends here.
}
```

This is the main routine of the node. Its content is calculated repeatedly for each `count`, making it an argument of the loop.

In this node, the value of `PARAM1` is only passed to the next and therefore only the information of a current loop is required. To calculate an average value over plural loops, it is necessary to have buffers for several frames. Details are described later.

The value with which `*(outputs[output1ID].buffer)[count] = ObjectRef(Int:: alloc(output1));` is output from the node. (The output of a port designated in `ID` specified by `count`-th “`output1ID`” is regulated.) Since this node is has one output, the output can be expressed as `out[count] = ObjectRef(Int:: alloc(output1))` although it is expressed as above in general cases. (In the case of one output, `*(outputs[output1ID].buffer)` is equivalent to `out`.)

`output1`, of `int` type, is cast into `Int` type, making all variable types related to inputs and outputs of `Int` type, `Float` type, `String` type, `Bool` type, `Vector` type, `Matrix` type and `Map` type, the unique types for HARK . Examples are shown below.

- `int` type  
`*(outputs[output1ID].buffer)[count]= ObjectRef(Int::alloc(output1));`
- `float` type  
`*(outputs[output1ID].buffer)[count]= ObjectRef(Float::alloc(output1));`
- `bool` type  
`*(outputs[output1ID].buffer)[count]= TrueObject;`
- `string` type  
`*(outputs[output1ID].buffer)[count]= ObjectRef(new String(output1));`
- `Vector` type  
`RCPtr<Vector<float>> > output1(new Vector<float>(rows));`  
`*(outputs[output1ID].buffer)[count]= output1;`  
 (`rows` is the number of elements of the vector. `Vector<int>` can also be defined. Inclusion of `Vector.h` is required)
- `Matrix` type  
`RCPtr<Matrix<float>> > output1(new Matrix<float>(rows, cols));`  
`*(outputs[output1ID].buffer)[count]= output1;`  
 (`rows, cols` are the number of matrixes. `Matrix<int>` can also be defined. Inclusion of `Matrix.h` is required)

Here, `RCPtr` is an object smart pointer for HARK . This pointer is passed for inputs and outputs of arrays such as `Matrix` and `Vector` .

Install PublisherInt.cc

Compile the source and install it so that `PublisherInt.cc` can be used in HARK . First, add

```
PublisherInt.cc \
```

to an appropriate position in the `lib****_la_SOURCES` variable of `{${PACKAGE}}/hark_test/src/Makefile.am` (`****` is an arbitrary package. `hark_test` for this example) Make sure to add “\”.

In

```
> cd ${PACKAGE}/hark_test/
```

set

```
> autoreconf; ./configure --prefix=${install_dir}; make; make install;
```

and install it. (For `{${install_dir}}`, follow your own setting; e.g. `/usr`).

Start HARK-Designer.

```
> hark_designer
```

When GUI starts, confirm if there is a node created by

```
Node list > HARK\_TEST > PublishInt
```

Now the installation is completed. The following shows trouble shooting steps to perform if the above are not displayed.

- Confirm that the directory designated in `./configure --prefix=/**` is the value of `/usr/local/lib/hark/toolbox` or `/usr/lib/hark/toolbox`. Since HARK reads the def file in its own installed directory, it ignores this file when it is present in other directories.
- Confirm that the script that compiles the node has been created in `{${PACKAGE}}/hark_test/src/Makefile`. Confirm that `autoreconf` has been performed properly and that `Makefile` has been rewritten properly.
- Confirm that the node name is same as the class name in the source of the cc file. If they are not the same, they may be compiled but not displayed in GUI.

#### Creation of `SubscriberInt.cc`

Create `SubscriberInt.cc`, which inputs an integer output from `PublisherInt.cc` and discharge it without changing it. Cut and paste the following source code into `{${PACKAGE}}/hark_test/src/SubscriberInt.cc`.

---

```
#include <iostream>
#include <BufferedNode.h>
#include <Buffer.h>

using namespace std;
using namespace HARK;

class SubscriberInt;

DECLARE_NODE(SubscriberInt);
/*Node
 *
 * @name SubscriberInt
 * @category HARK_TEST
 * @description This block inputs an integer and outputs the same number with print.
 *
 * @input_name INPUT1
 * @input_type int
 * @input_description input for an integer
 *
 * @output_name OUTPUT1
 * @output_type int
 * @output_description Same as input
 *
END*/

class SubscriberInt : public BufferedNode {
    int input1ID;
    int output1ID;
    int input1;

public:
    SubscriberInt(string nodeName, ParameterSet params): BufferedNode(nodeName, params)
```

```

{
  input1ID= addInput("INPUT1");
  output1ID= addOutput("OUTPUT1");
  input1 = 0;inOrder = true;
}

void calculate(int output_id, int count, Buffer &out)
{
  // Main loop routine starts here.
  ObjectRef inputtmp = getInput(input1ID, count);
  input1 = dereference_cast<int> (inputtmp);
  cout << "Subscribed : [" << count << " , " << input1 << "]" << endl;
  (*(outputs[output1ID].buffer))[count] = ObjectRef(Int::alloc(input1));
  // Main loop routine ends here.
}
};

```

Although it is similar to `PublisherInt.cc`, we will focus on the differences.

```

* @input_name INPUT1
* @input_type int
* @input_description input for an integer

```

Although `PublisherInt.cc` does not have an input port, an input requires that GUI of HARK-Designer be set first. Its format is basically the same as that of `@output`. Since `SubscriberInt.cc` has one input, the following is indicated in HARK-Designer .

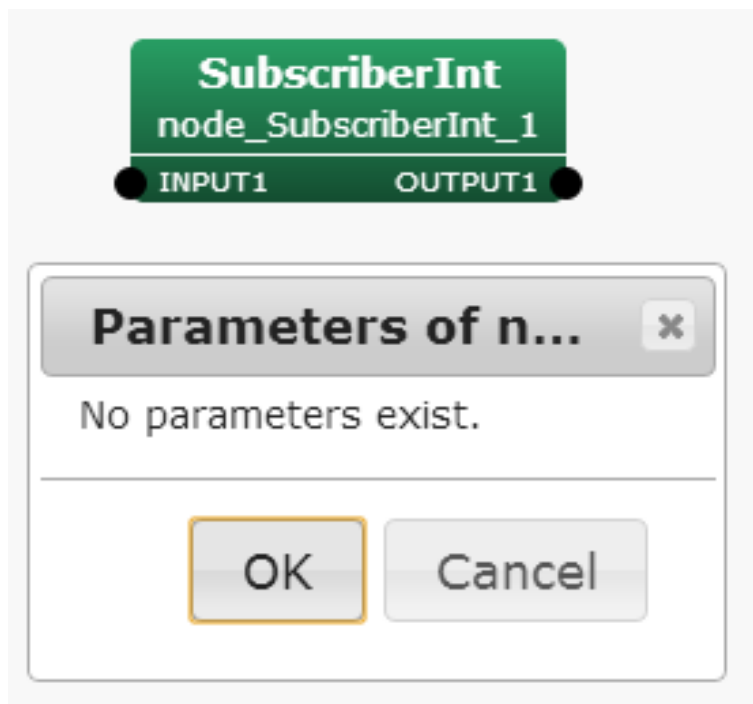

Figure 13.2: SubscriberInt node

```

input1ID= addInput("INPUT1");

```

This code registers the ID `INPUT1` set in the GUI as `input1ID` defined in the `cc` file and allocates the GUI port to input data.

```

ObjectRef inputtmp = getInput(input1ID, count);
input1 = dereference_cast<int> (inputtmp);

```

Data are received from the input port corresponding to its ID as an original type of HARK and are cast into `int` type. Like `ObjectRef` (`Int` type, `Float` type, `Bool` type, `String` type, etc...), an original HARK variable type is passed in the output port, with recasting performed in the receiving node in the above process. The following shows examples for other types.

- int type  

```
ObjectRef inputtmp = getInput(input1ID, count);
input1 = dereference_cast<int> (inputtmp);
```
- float type  

```
ObjectRef inputtmp = getInput(input1ID, count);
input1 = dereference_cast<float> (inputtmp);
```
- bool type  

```
ObjectRef inputtmp = getInput(input1ID, count);
input1 = dereference_cast<bool> (inputtmp);
```
- string type  

```
ObjectRef inputtmp = getInput(input1ID, count);
const String &input1 = object_cast<String> (inputtmp);
(input1 is string type here)
```
- Vector type  

```
RCPtr<Vector<float> > input1 = getInput(input1ID, count);
((*input1)[i] at the time of use. Same for Vector<int>.)
```
- Matrix type  

```
RCPtr<Matrix<float> > input1 = getInput(input1ID, count);
((*input1)(i,j) at the time of use. Same for Matrix<int>.)
```

The output port setting is same as for `PublisherInt.cc`. When finishing its creation, install it by source compilation using the same procedure as that described in the preceding chapter. Start HARK-Designer and confirm that `SubscriberInt.cc` has been installed properly.

Create network files with `PublisherInt.cc` and `SubscriberInt.cc`

Now, we will show how to create a network file (N file) in HARK using `PublisherInt.cc` and `SubscriberInt.cc`. The network file is show below; if you understand this figure, you do not need to read the rest of this chapter, so proceed to the next chapter.



(a) MAIN(subnet) Sheet

(b) LOOP0(iterator) Sheet

Figure 13.3: PublisherInt + SubscriberIntnetwork file

First, start HARK-Designer. For a new file, only the MAIN sheet will appear when starting-up. This is the main process in the program flow.

Plus Button(Add a new sheet) > Type Iterator

Add a loop processing sheet. Pick a proper sheet name (LOOP0 here). First, in the MAIN sheet side,

Node list > Dynamic > LOOP0

so that LOOPO can be executed from the MAIN. Move to the LOOPO sheet and determine the sampling period of repetition processing (both event-based and time-based loops are possible). Here, we perform time-based repeat calculations with Sleep.

```
Node list > Flow > Sleep (Put the Sleep node in the sheet)
Double-click Sleep > Set parameter \verb|SECONDS| properly (e.g. 1.0) > OK
Right-Click the output-terminal of Sleep and select "Set as condition"
```

Confirm that the output-terminal of Sleep has become CONDITION. This is a trigger of loop processing, indicating that a new loop begins when the processing of Sleep is completed. The main processing is described next.

Put two nodes in the LOOPO sheet.

```
Node list > HARK_TEST > PublisherInt
Node list > HARK_TEST > SubscriberInt
```

```
Double-click PublishInt > Set PARAM1 of PublisherInt (e.g. 123) > OK
Connect the output-terminal of PublisherInt to the input of SubscriberInt
Right-click the output-terminal of SubscriberInt and select "Set as output"
```

Confirm that the output-terminal of SubscriberInt has become OUTPUT1. This is the output of loop processing. One output is created in the LOOPO block of the MAIN sheet by adding this OUTPUT1 to the output. Go back to the MAIN sheet, and set it as follows.

```
Right-click the output-terminal of LOOPO and select "Set as output"
```

Then OUTPUT1 will become the output from the MAIN sheet, enabling LOOPO to operate.

```
Save the file using an arbitrary name
Press "Execute"
```

The following output will appear in the console.

```
Published :
[0 , 123]
Subscribed :
[0 , 123]
Published :
[1 , 123]
Subscribed :
[1 , 123]
Published :
[2 , 123]
Subscribed :
[2 , 123]
...
```

The network file that can exchange integers has been completed. The above is a basic tutorial for creating nodes. Further techniques, such as the addition of inputs and outputs and processing between multiple frames, will be described below.

Adding internal parameters to a node

There is one property parameter called PARAM1 in PublisherInt.cc. This section describes how to change PublisherInt.cc to arrange multiple parameters. Since the use of simple int type has been described, this section describes how to read Vector type, which is more difficult as a parameter (the new parameter is named PARAM2). The goal is to read a Vector type variable as a parameter, multiply it by PARAM1 as shown below and modify the node so that the result is output from the output port.

```
PARAM1 * PARAM2
```

This tutorial involves two elements: 1) addition of an internal parameter in Vector type, and 2) addition of an output port in Vector type. Therefore, the two are described in two independent chapters. This chapter describes how to add an internal parameter. Open {PACKAGE}/hark\_test/src/PublisherInt.cc. Since we are dealing with a Vector type variable, include Vector.h first.

```
#include <Vector.h>
```

Change the GUI setting of HARK-Designer. Add the following in `/*Node ... END*/`.

```
*
* @parameter_name PARAM2
* @parameter_type Vector<int>
* @parameter_value <Vector<int> 0 1 2>
* @parameter_description OUTPUT2 = PARAM1 * PARAM2
*
```

Here, see `@parameter_value`. The format of `<Vector<int> 0 1 2>` is strict (e.g. spaces). Next, add the following to the member variables of the class.

```
Vector<int> param2;
```

Add the following in the constructor.

```
param2 = object_cast<Vector<int> >(parameters.get("PARAM2"));
```

Then, it can be used as `Vector`, as shown in the following example.

```
for(int i = 0;i < param2.size();i++){cout << param2[i]<< " "};}
```

Although this section described changes only with sentences, the finalized source code is shown in the last part of the next section.

#### Adding output to a node

The previous section described how to read variables of `Vector` type as internal parameters. In this section, `PARAM1` is multiplied by the `Vector` type variable, and `PublisherInt.cc` is modified so that it can output a `Vector` type variable. First, add the output for GUI of HARK-Designer:

```
*
* @output_name OUTPUT2
* @output_type Vector<int>
* @output_description OUTPUT2 = PARAM1 * PARAM2
*
```

Next, add a variable for an ID of the output port to the member variables of the class.

```
int output2ID;
```

Add the following in the constructor.

```
output2ID = addOutput("OUTPUT2");
```

Set the output in the main routine of `calculate`.

```
RCPtr<Vector<int> > output2(new Vector<int>(param2.size()));
(*(outputs[output2ID].buffer))[count]= output2;
```

Here, since we are calculating `PARAM1 * PARAM2`, the number of components in the output vector is the same as that of `PARAM2`. Therefore, the size of `output2` is the same as that of `param2.size()`. Substitute `PARAM1 * PARAM2` for `output2`.

```
for(int i = 0;i < param2.size();i++){
    (*output2)[i]= param1 * param2[i];
}
```

The results of `PARAM1 * PARAM2` are output from `OUTPUT2`. The finalized edition of `PublisherInt.cc` is shown below.

---

```

#include <iostream>
#include <BufferedNode.h>
#include <Buffer.h>
#include <Vector.h>

using namespace std;
using namespace HARK;

class PublisherInt;

DECLARE_NODE(PublisherInt);
/*Node
 *
 * @name PublisherInt
 * @category HARK_TEST
 * @description This block outputs the same integer as PARAM1.
 *
 * @output_name OUTPUT1
 * @output_type int
 * @output_description This output the same integer as PARAM1.
 *
 * @output_name OUTPUT2
 * @output_type Vector<int>
 * @output_description OUTPUT2 = PARAM1 * PARAM2
 *
 * @parameter_name PARAM1
 * @parameter_type int
 * @parameter_value 123
 * @parameter_description Setting for OUTPUT1
 *
 * @parameter_name PARAM2
 * @parameter_type Vector<int>
 * @parameter_value <Vector<int> 0 1 2>
 * @parameter_description OUTPUT2 = PARAM1 * PARAM2
 *
 *
 */
END*/

class PublisherInt : public BufferedNode {
    int output1ID;
    int output2ID;
    int output1;
    int param1;
    Vector<int> param2;

public:
    PublisherInt(string nodeName, ParameterSet params) : BufferedNode(nodeName, params)
    {
        output1ID= addOutput("OUTPUT1");
        output2ID= addOutput("OUTPUT2");
        output1 = 0;
        param1 = dereference_cast<int>(parameters.get("PARAM1"));
        param2 = object_cast<Vector<int> >(parameters.get("PARAM2"));
        inOrder = true;
    }

    void calculate(int output_id, int count, Buffer &out)
    {
        // Main loop routine starts here.

        output1 = param1;
        cout << "Published :[" << count << " , " << output1 << "]" << endl;
        (*(outputs[output1ID].buffer))[count]= ObjectRef(Int::alloc(output1));

        RCPtr<Vector<int> > output2(new Vector<int>(param2.size()));
        (*(outputs[output2ID].buffer))[count]= output2;
        cout << "Vector Published :[";
        for(int i = 0;i < param2.size();i++){
            (*output2)[i]= param1 * param2[i];
            cout << (*output2)[i]<< " ";
        }
        cout << "]" << endl;

        // Main loop routine ends here.
    }
};

```

---

### Adding input to a node

We have described a method of outputting a variable of Vector type to the new `PublisherInt.cc`. This chapter describes how to create a new `SubscriberInt.cc` that receives a Vector type variable as an input.

Open `{${PACKAGE}}/hark_test/src/SubscriberInt.cc` using an appropriate editor. Since a `Vector` type variable is treated, include `Vector.h` first.

```
#include <Vector.h>
```

Change the GUI setting of HARK-Designer. Add the following in `/*Node ... END*/`.

```
*  
* @input_name INPUT2  
* @input_type Vector<int>  
* @input_description input for a Vector  
*
```

Add a member variable of the class.

```
int input2ID;
```

Add the following to the constructor.

```
input2ID= addInput("INPUT2");
```

Read input data in `calculate`.

```
RCPtr<Vector<int> > input2 = getInput(input2ID, count);
```

Then, `input2` can be used in the main routine:

```
for(int i = 0;i < (*input2).size();i++){  
    cout << (*input2)[i]<< " ";  
}
```

The finalized edition of `SubscriberInt.cc` is shown below.

---

```

#include <iostream>
#include <BufferedNode.h>
#include <Buffer.h>
#include <Vector.h>

using namespace std;
using namespace HARK;

class SubscriberTutorial;

DECLARE_NODE(SubscriberTutorial);
/*Node
 *
 * @name SubscriberTutorial
 * @category HARKD:Tutorial
 * @description This block inputs an integer and outputs the same number with print.
 *
 * @input_name INPUT1
 * @input_type int
 * @input_description input for an integer
 *
 * @input_name INPUT2
 * @input_type Vector<int>
 * @input_description input for a Vector
 *
 * @output_name OUTPUT1
 * @output_type int
 * @output_description Same as input
 *
END*/

class SubscriberTutorial : public BufferedNode {
    int input1ID;
    int input2ID;
    int output1ID;
    int input1;

public:
    SubscriberTutorial(string nodeName, ParameterSet params) : BufferedNode(nodeName, params)
    {
        input1ID= addInput("INPUT1");
        input2ID= addInput("INPUT2");
        output1ID= addOutput("OUTPUT1");
        input1 = 0;inOrder = true;
    }

    void calculate(int output_id, int count, Buffer &out)
    {
        // Main loop routine starts here.

        ObjectRef inputtmp = getInput(input1ID, count);
        input1 = dereference_cast<int> (inputtmp);
        cout << "Subscribed :[" << count << " , " << input1 << "]" << endl;

        (*(outputs[output1ID].buffer))[count] = ObjectRef(Int::alloc(input1));
        RCPtr<Vector<int> > input2 = getInput(input2ID, count);
        cout << "Vector Received :[";

        for(int i = 0;i < (*input2).size();i++){
            cout << (*input2)[i]<< " ";
        }
        cout << "]" << endl;

        // Main loop routine ends here.
    }
};

```

---

Create an N file with new PublisherInt.cc and SubscriberInt.cc

The fundamental procedure is same as that for N file creation described in the previous section. First, confirm if compilation and installation were performed properly. If successful, start HARK-Designer. Open the N file created in the previous section. Confirm that: 1) OUTPUT2 has been added to the output ports of the PublisherInt node, and 2) INPUT2 has been added to the input ports of the SubsciberInt node. (If these cannot be confirmed, installation was not successful, so trouble-shoot the problem as described in the previous section.) After connecting the two, utilize the following setting:

Double-click PublishInt > Set type of PARAM2 to "object" > OK

Save it and press "Execute".

```

Published :
[0 , 123]
Vector Published :
[0 123 246 ]
Subscribed :
[0 , 123]
Vector Received :
[0 123 246 ]
Published :
[1 , 123]
Vector Published :
[0 123 246 ]
Subscribed :
[1 , 123]
Vector Received :
[0 123 246 ]
Published :
[2 , 123]
Vector Published :
[0 123 246 ]
Subscribed :
[2 , 123]
Vector Received :
[0 123 246 ]
...

```

The above is displayed in the console. Confirm that `Vector` is exchanged correctly. The following is the capture of the node created.

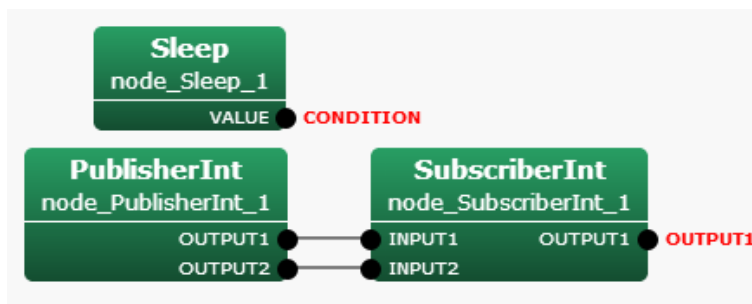

Figure 13.4: SubscriberInt + PublisherInt network file

Processing over multiple frames (lookBack and lookAhead options)

The above sections have described calculations within a frame, such as multiplying a vector by a constant. However, calculations over multiple frames (e.g. means) or differentiation requires processing *over* multiple frames. For example, to create a block to obtain the total of input values from two frames before to two frames after the current frame (total of five frames):

$$OUTPUT1(t) = INPUT1(t-2) + INPUT1(t-1) + INPUT1(t) + INPUT1(t+1) + INPUT1(t+2) \quad (13.1)$$

Since `getInput` is maintained for each ID and `count` value of the input port, it can be calculated as:

```

total = 0.0;
for(int i = -2;i <= 2;i++){
    ObjectRef inputtmp = getInput(input1ID, count + i);
    input1 = dereference_cast<int> (inputtmp);
    total += input1;
}

```

Here, the argument of `getInput` is expressed as "count + i", allowing processing from two frames before to two frames after the current frame. Errors during execution are due, first, to the `count` value having to be -2 and -1 in the first and second frames, respectively, resulting in a negative `count` value. This problem can be resolved simply by adding the following.

```

if(count >= 2)

```

The second reason is that in HARK, unless particularly requested, only one frame before and one frame after the current frame are maintained during the process. Therefore, trying to see more than two frames away causes an error of undefined frames. This can be solved by describing the following in the constructor, enabling the buffer to maintain information for the desired number of frames.

```

inputsCache[input1ID].lookAhead = 2;
inputsCache[input1ID].lookBack = 2;

```

The above is a command to take buffers from the two frames before and after the current frame. Set them adequately for your own purposes. This allows calculations for multiple frames. The following is the "AccumulationInt" node that takes an `int` type input and acquires a total number of frames, from `SUM_BACKWARD` frames before and `SUM_FORWARD` frames after the current frame. Since `lookAhead` and `lookBack` can be changed, errors will occur unless a sufficient number of frames are included in the buffer. An example of a network file is shown below.

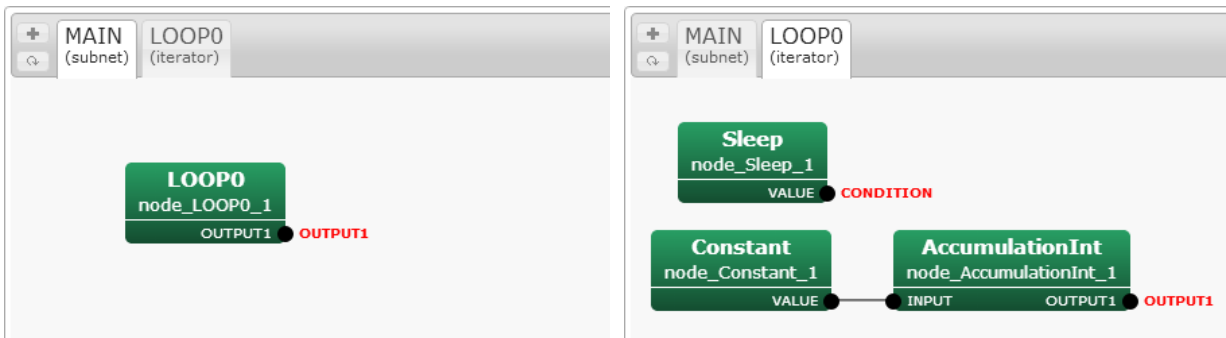

(a) MAIN(subnet) Sheet

(b) LOOP0(iterator) Sheet

Figure 13.5: AccumulationInt network file

```

#include <iostream>
#include <BufferedNode.h>
#include <Buffer.h>

using namespace std;
using namespace HARK;

class AccumulationInt;

DECLARE_NODE(AccumulationInt);
/*Node
 *
 * @name AccumulationInt
 * @category HARKD:Tutorial
 * @description This block takes a summation over several frames of the input.
 *
 * @input_name INPUT1
 * @input_type int
 * @input_description input for an integer
 *
 * @output_name OUTPUT1
 * @output_type int
 * @output_description total
 *
 * @parameter_name SUM_FORWARD
 * @parameter_type int
 * @parameter_value 5
 * @parameter_description Forward buffer for summation
 *
 * @parameter_name SUM_BACKWARD
 * @parameter_type int
 * @parameter_value -5
 * @parameter_description Backward buffer for summation
 *
 * @parameter_name LOOK_FORWARD
 * @parameter_type int
 * @parameter_value 0
 * @parameter_description Forward buffer for summation
 *
 * @parameter_name LOOK_BACKWARD
 * @parameter_type int
 * @parameter_value 0
 * @parameter_description Backward buffer for summation
 *
 * @parameter_name IN_ORDER
 * @parameter_type bool
 * @parameter_value true
 * @parameter_description inOrder setting
 *
END*/

class AccumulationInt : public BufferedNode {
    int input1ID;
    int output1ID;
    int input1;
    int sum_forward;
    int sum_backward;
    int look_forward;
    int look_backward;
    int total;
    bool in_order;

public:
    AccumulationInt(string nodeName, ParameterSet params) : BufferedNode(nodeName, params)
    {
        input1ID= addInput("INPUT1");
        output1ID= addOutput("OUTPUT1");
        input1 = 0;
        sum_forward = dereference_cast<int>(parameters.get("SUM_FORWARD"));
        sum_backward = dereference_cast<int>(parameters.get("SUM_BACKWARD"));
        look_forward = dereference_cast<int>(parameters.get("LOOK_FORWARD"));
        look_backward = dereference_cast<int>(parameters.get("LOOK_BACKWARD"));
        inputsCache[input1ID].lookAhead = look_forward;
        inputsCache[input1ID].lookBack = look_backward;
        in_order = dereference_cast<bool>(parameters.get("IN_ORDER"));
        inOrder = in_order;
    }

    void calculate(int output_id, int count, Buffer &out)
    {
        total = 0;
        if(count + sum_backward >= 0){
            for(int i = sum_backward; i <= sum_forward; i++){
                ObjectRef inputtmp = getInput(input1ID, count + i);
                input1 = dereference_cast<int>(inputtmp);
                total += input1;
            }
        }
        cout << "AccumulationInt :[" << count << " , " << input1 << " , " << total << "]" << endl;
        (*(outputs[output1ID].buffer))[count]= ObjectRef(Inputs::alloc(total));
    }
};

```

---

Processing that does not calculate every frame (inOrder option)

In contrast to the previous section, this chapter describes processing performed once in several frames. For example, consider the following source.

```
if(count % 3 == 0){
    ObjectRef inputtmp = getInput(input1ID, count);
    input1 = dereference_cast<int> (inputtmp);
}
```

In this case, `getInput` is not read for every `count`, but once in three frames. In HARK , the former node is processed in accordance with the request from the `getInput`. That is, with a source like the above, the node request inputs once in three frames. Therefore, its former node is calculated once in three frames. The following is an example. First, as a preparation, create the following `SubscriberIntWithPeriod` node.

---

```

#include <iostream>
#include <BufferedNode.h>
#include <Buffer.h>

using namespace std;
using namespace HARK;

class SubscriberIntWithPeriod;

DECLARE_NODE(SubscriberIntWithPeriod);
/*Node
 *
 * @name SubscriberIntWithPeriod
 * @category HARKD:Tutorial
 * @description This block inputs an integer and outputs the same number with print with specific period.
 *
 * @input_name INPUT1
 * @input_type int
 * @input_description input for an integer
 *
 * @output_name OUTPUT1
 * @output_type int
 * @output_description Same as input
 *
 * @parameter_name PERIOD
 * @parameter_type int
 * @parameter_value 1
 * @parameter_description Period of INPUT1 subscription
 *
 * @parameter_name IN_ORDER
 * @parameter_type bool
 * @parameter_value true
 * @parameter_description inOrder setting
 *
END*/

class SubscriberIntWithPeriod : public BufferedNode {
    int input1ID;
    int output1ID;
    int input1;
    int period;
    bool in_order;

public:
    SubscriberIntWithPeriod(string nodeName, ParameterSet params) : BufferedNode(nodeName, params){
        input1ID= addInput("INPUT1");
        output1ID= addOutput("OUTPUT1");
        input1 = 0;
        period = dereference_cast<int>(parameters.get("PERIOD"));
        in_order =dereference_cast<bool> (parameters.get("IN_ORDER"));
        inOrder = in_order;
    }

    void calculate(int output_id, int count, Buffer &out){
        // Main loop routine starts here.
        if(count % period == 0){
            ObjectRef inputtmp = getInput(input1ID, count);
            input1 = dereference_cast<int> (inputtmp);
        }
        cout << "Subscribed :[" << count << " , " << input1 << "]" << endl;
        (*(outputs[output1ID].buffer))[count]= ObjectRef(Int::alloc(input1));
        // Main loop routine ends here.
    }
};

```

---

In the `SubscriberIntWithPeriod` node, `getInput` is performed over the period set in `PERIOD`, and its value is displayed. Next, create the `CountOutput` node to output the current `count` value without changing it.

---

```

#include <iostream>
#include <BufferedNode.h>
#include <Buffer.h>

using namespace std;
using namespace HARK;

class CountOutput;

DECLARE_NODE(CountOutput);
/*Node
 *
 * @name CountOutput
 * @category HARKD:Tutorial
 * @description This block outputs the count number
 *
 * @output_name OUTPUT1
 * @output_type int
 * @output_description This output the same integer as PARAM1.
 *
 * @parameter_name IN_ORDER
 * @parameter_type bool
 * @parameter_value true
 * @parameter_description inOrder setting
 *
END*/

class CountOutput : public BufferedNode {
    int output1ID;
    bool in_order;

public:
    CountOutput(string nodeName, ParameterSet params): BufferedNode(nodeName, params)
    {
        output1ID= addOutput("OUTPUT1");
        in_order = dereference_cast<bool> (parameters.get("IN_ORDER"));
        inOrder = in_order;
    }

    void calculate(int output_id, int count, Buffer &out){
        cout << "CountOut :[" << count << "]" << endl;
        (*(outputs[output1ID].buffer))[count] = ObjectRef(Int::alloc(count));
    }
};

```

When the two nodes are completed, build a network file of HARK-Designer.

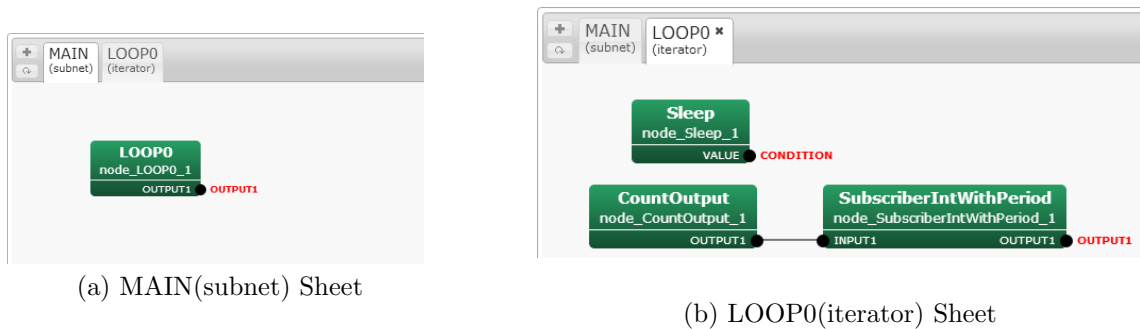

(a) MAIN(subnet) Sheet

(b) LOOP0(iterator) Sheet

Figure 13.6: SubscriberIntWithPeriod network file

First, set `IN_ORDER` of both `CountOutput` and `SubscriberIntWithPeriod` to "false" (These are default settings). Set `PERIOD` of `SubscriberIntWithPeriod` as 3, and execute the network file. The output of the console will be:

```
CountOut :
[0]
Subscribed :
[0 , 0]
Subscribed :
[1 , 0]
Subscribed :
[2 , 0]
CountOut :
[3]
Subscribed :
[3 , 3]
Subscribed :
[4 , 3]
Subscribed :
[5 , 3]
CountOut :
[6]
Subscribed :
[6 , 6]
Subscribed :
[7 , 6]
Subscribed :
[8 , 6]
CountOut :
[9]
Subscribed :
[9 , 9]
...
```

Thus, since the latter `SubscriberIntWithPeriod` request inputs once in three frames, `CountOut` will be processed only once every three frames. If processing such as differentiation or count calculation is performed in `CountOut`, the process cannot be performed correctly. (To confirm this problem, implement a counter that counts every time `calculate` is called by the `CountOut` node. This will confirm that the counter does not work for all `count`.) The "inOrder" option solves this problem. Set `IN_ORDER` to `true` in the abovementioned network file. When executed, the following result is obtained:

```

CountOut :
[0]
Subscribed :
[0 , 0]
Subscribed :
[1 , 0]
Subscribed :
[2 , 0]
CountOut :
[1]
CountOut :
[2]
CountOut :
[3]
Subscribed :
[3 , 3]
Subscribed :
[4 , 3]
Subscribed :
[5 , 3]
CountOut :
[4]
CountOut :
[5]
CountOut :
[6]
Subscribed :
[6 , 6]
Subscribed :
[7 , 6]
Subscribed :
[8 , 6]
CountOut :
[7]
CountOut :
[8]
CountOut :
[9]
Subscribed :
[9 , 9]
...

```

Thus, loop processing is properly executed for `CountOut` three times, in agreement with the requirement that it be performed once every three frames. To properly calculate the number of `count` times for all nodes, regardless of requirements, enter the following into the constructor:

```
inOrder = true;
```

#### Creating a node that takes a dynamic number of inputs (`translateInput`)

This section describes how to create a node that takes a dynamic number of inputs. The following example takes three `int` type inputs and calculates their total.

---

```

#include <iostream>
#include <BufferedNode.h>
#include <Buffer.h>

using namespace std;
using namespace HARK;

class SummationInt;

DECLARE_NODE(SummationInt);
/*Node
 *
 * @name SummationInt
 * @category HARKD:Tutorial
 * @description This block outputs INPUT1 + INPUT2 + INPUT3
 *
 * @input_name INPUT1
 * @input_type int
 * @input_description input for an integer
 *
 * @input_name INPUT2
 * @input_type int
 * @input_description input for an integer
 *
 * @input_name INPUT3
 * @input_type int
 * @input_description input for an integer
 *
 * @output_name OUTPUT1
 * @output_type int
 * @output_description Same as input
 *
END*/

class SummationInt : public BufferedNode {
int input1ID;
int input2ID;
int input3ID;
int output1ID;
int input1;
int input2;
int input3;
int total;

public:
SummationInt(string nodeName, ParameterSet params) : BufferedNode(nodeName, params){
input1ID= addInput("INPUT1");
input2ID= addInput("INPUT2");
input3ID= addInput("INPUT3");
output1ID = addOutput("OUTPUT1");
inOrder = true;
}

void calculate(int output_id, int count, Buffer &out){
// Main loop routine starts here.

input1 = 0;
input2 = 0;
input3 = 0;
ObjectRef inputtmp1 = getInput(input1ID, count);
input1 = dereference_cast<int> (inputtmp1);
ObjectRef inputtmp2 = getInput(input2ID, count);
input2 = dereference_cast<int> (inputtmp2);
ObjectRef inputtmp3 = getInput(input3ID, count);
input3 = dereference_cast<int> (inputtmp3);
total = input1 + input2 + input3;
cout << "SummationInt :[" << count << " , " << total << "]" << endl;
*(outputs[output1ID].buffer)[count]= ObjectRef(Int::alloc(total));

// Main loop routine ends here.
}
};

```

---

When the node is created, create a network file as follows.

In this case,  $1+1+1$ , so 3 is the result. Currently, this node *has to* take three inputs. Now, suppose that you wish to sum *two* variables from this node, not all three. It thus appears that these calculations can be performed by opening one input port and giving integers to two ports, as shown in the following figure. However, when executing, an error occurred because the node requires all input ports to be connected.

In HARK , except in special cases, all information about the input ports read in `getInput` must be received, even if all the data are not used for processing inside the node. To realize the dynamic number of inputs, you can use a method called `translateInput`, which is in the member function of the `Node` class,

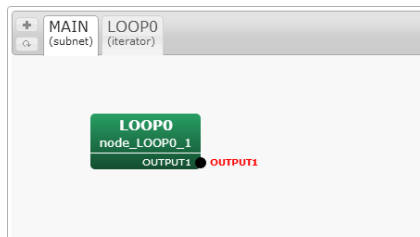

(a) MAIN(subnet) Sheet

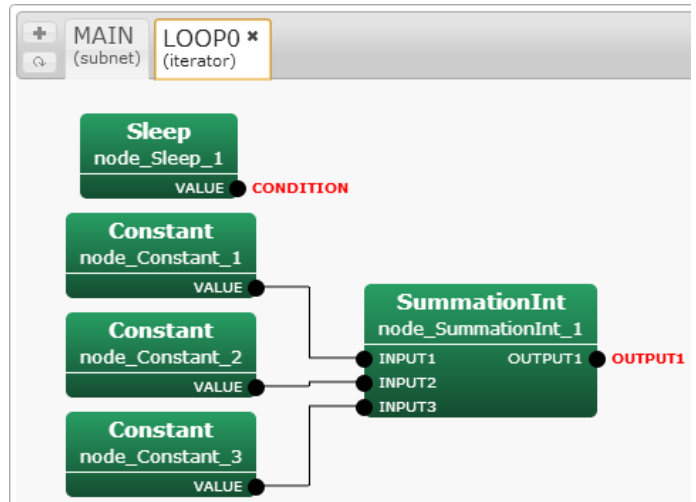

(b) LOOP0(iterator) Sheet

Figure 13.7: SummationInt network file

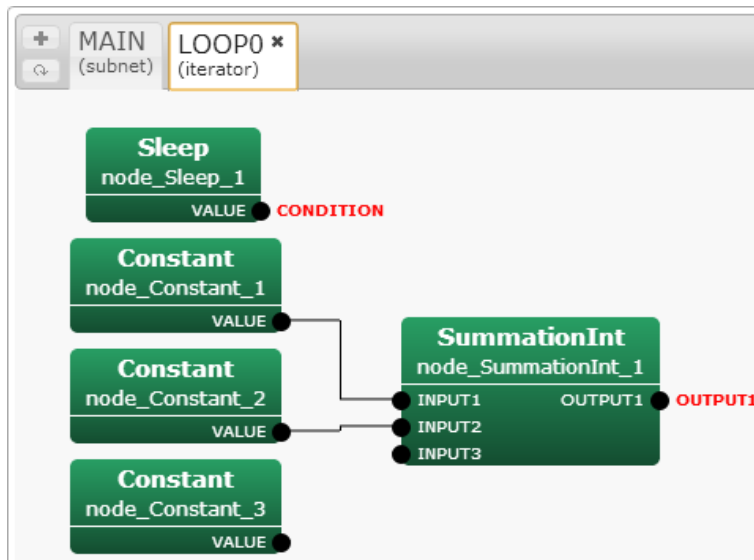

Figure 13.8: SummationInt network file (input port imperfection)

which is a parent class of `BufferedNode`. To create a node in which the number of input ports varies with the same example.

---

```

#include <iostream>
#include <BufferedNode.h>
#include <Buffer.h>

using namespace std;
using namespace HARK;

class SummationInt;

DECLARE_NODE(SummationInt);
/*Node
 *
 * @name SummationInt
 * @category HARKD:Tutorial

```

```

* @description This block outputs INPUT1 + INPUT2 + INPUT3
*
* @input_name INPUT1
* @input_type int
* @input_description input for an integer
*
* @input_name INPUT2
* @input_type int
* @input_description input for an integer
*
* @input_name INPUT3
* @input_type int
* @input_description input for an integer
*
* @output_name OUTPUT1
* @output_type int
* @output_description Same as input
*
END*/

class SummationInt : public BufferedNode {
    int input1ID;
    int input2ID;
    int input3ID;
    int output1ID;
    int input1;
    int input2;
    int input3;
    int total;

public:
    SummationInt(string nodeName, ParameterSet params)
        : BufferedNode(nodeName, params), input1ID(-1), input2ID(-1), input3ID(-1)
    {
        output1ID= addOutput("OUTPUT1");
        inOrder = true;
    }

    virtual int translateInput(const string &inputName){
        if (inputName == "INPUT1"){return input1ID = addInput(inputName);}
        else if (inputName == "INPUT2"){return input2ID = addInput(inputName);}
        else if (inputName == "INPUT3"){return input3ID = addInput(inputName);}
        else {throw new NodeException(this, inputName+ " is not supported.", __FILE__, __LINE__);}
    }

    void calculate(int output_id, int count, Buffer &out){
        // Main loop routine starts here.
        input1 = 0;
        input2 = 0;
        input3 = 0;
        if (input1ID != -1){
            ObjectRef inputtmp1 = getInput(input1ID, count);
            input1 = dereference_cast<int> (inputtmp1);
        }
        if (input2ID != -1){
            ObjectRef inputtmp2 = getInput(input2ID, count);
            input2 = dereference_cast<int> (inputtmp2);
        }
        if (input3ID != -1){
            ObjectRef inputtmp3 = getInput(input3ID, count);
            input3 = dereference_cast<int> (inputtmp3);
        }
        total = input1 + input2 + input3;
        cout << "SummationInt :[" << count << " , " << total << "]" << endl;
        (*(outputs[output1ID].buffer))[count] = ObjectRef(Int::alloc(total));
        // Main loop routine ends here.
    }
};

```

---

The changes are as follows.

- The input port ID is initialized with -1 in the constructor.  
Thus, the ID will be kept at -1 unless the input port is connected.
- Added `translateInput`.  
This function detects which ports are connected. If an input port is connected, its ID will be acquired.
- Processing is performed in `calculate` for the input ports whose value is other than -1.  
This allows processing of examples in which the input is either opened or unopened.

Compiling this source and using it in HARK will show that the calculation has been performed properly, without depending on the number of inputs.

See Also

- Installation from source compilation  
See "Installation of HARK" in the HARK training session material
- How to make a basic node  
See "Creation of a node" in the HARK training session material

## 13.2 Improving the processing speed

### Problem

How can I increase the computing speed of HARK?

### Solution

The processing speed of HARK is dominated basically by the complexity of the nodes and their algorithms created by the user. As examples, the more you process eigenvalue expansion in `LocalizeMUSIC`, save of `SaveFeatures` or indications by `cout` and `cerr`, the longer the processing time required for one count. The simplest way of increasing processing speed is to construct simple nodes. (Algorithms have been improved for current HARK nodes to increase the speed of real time processing.) Two other methods can improve processing speed, although the improvements would be slight.

1) `Comment-in IN_ORDER_NODE_SPEEDUP`

This function acts at the end of a node class. (Comment-in is described concretely in cc files such as `LocalizeMUSIC`)

2) Change the optimization option for compiling.

Add this option while constructing the node. Optimization is performed with a stronger condition, in the order `-O`, `-O1`, `-O2`, and `-O3`, with processing speeds increasing accordingly.

Concretely, in the case of `-O2`,

`/src/Makefile.am`

Add the following to the above

```
libhark_d_la_CXXFLAGS = @GTK_CFLAGS@ -O2
CXXFLAGS = -g -O2
CFLAGS = -g -O2
FFLAGS = -g -O2
```

### Discussion

Evaluate the performance of each, by analyzing the patterns compiled with options of `-O`, `-O1`, `-O2`, and `-O3`, and those for which `IN_ORDER_NODE_SPEEDUP` is further added. Thus, the processing times of eight patterns are compared. For comparison, use the algorithm for simple processing for each node, with processing times measured in 100 nodes connected in series.

```
int count_time = 100000000;
for (i = 0; i < count_time; i++) n = n + i;
```

Tables 13.1 and 13.2 show results without and with `IN_ORDER_NODE_SPEEDUP`, respectively. Computing times did not differ significantly, with processing speeds being only 3 percent higher with a combination of an optimization option and `IN_ORDER_NODE_SPEEDUP`.

### See Also

None

Table 13.1: Elapsed Times without IN\_ORDER\_NODE\_SPEEDUP

Option	O3	O2	O1	O
	14.2408	12.7574	14.0147	14.1765
	13.9518	14.0789	14.2417	14.3901
	13.912	14.0633	14.5486	13.7121
	14.3929	13.9978	14.2038	14.1017
	13.7976	14.3931	13.8478	14.2374
	14.0315	13.9962	14.5201	14.1924
	14.3108	14.0069	14.1044	14.1694
	14.0055	14.3397	14.2014	14.5729
	14.004	14.0419	14.467	14.1911
	14.4457	13.8734	14.1159	14.2177
Total	141.0926	139.5486	142.2654	141.9613
Average	<b>14.10926</b>	<b>13.95486</b>	<b>14.22654</b>	<b>14.19613</b>

Table 13.2: Elapsed Times with IN\_ORDER\_NODE\_SPEEDUP

Option	O3 + speedup	O2 + speedup	O1 + speedup	O + speedup
	14.0007	13.8055	14.3469	14.4444
	14.3702	13.5448	13.9894	14.1628
	14.0753	14.371	14.4229	13.8679
	12.9333	13.8942	14.1801	14.5209
	14.398	13.8926	13.7115	14.0369
	13.6696	14.1745	14.5278	14.7882
	14.0837	14.0613	13.9905	14.5343
	14.4443	14.018	14.0915	14.1182
	13.0798	14.4962	14.4936	14.5952
	13.6339	14.1081	14.1904	14.2751
Total	138.6888	140.3662	141.9446	143.3439
Average	<b>13.86888</b>	<b>14.03662</b>	<b>14.19446</b>	<b>14.33439</b>

### 13.3 Connecting HARK to the other systems

#### Problem

I understand that sound source localization and sound source separation can be performed in HARK. How can I transfer the information to other systems? To answer this question, we consider the followings:

- Connection between two different HARK systems
- Connection with other systems through a socket connection
- Connection with ROS(Robot Operating System : <http://www.ros.org/wiki/>)

#### Solution 1

: Connection between two different HARK systems

Users may wish to process several HARK network files as submodules of one network file. For example, when performing parallel computations for the same algorithms, it is time consuming to describe all parallel module groups to one subnet sheet, and it would be fairly complicated since a large number of nodes must be treated. This section describes a method to treat one system described in the subnet sheet as one node.

##### 1) Create the network to be connected

You may add a subnet sheet to the existing network file as

"Networks" -> "Add Network"

, or you may use an existing network file. In this case, make sure to designate inputs and outputs for this sheet (it is not a MUST since inputs and outputs can be changed after connecting).

2) **Export the created subnet sheet (Note 1)**

Make the created sheet active, and click

"Networks" -> "Export Network".

Give it an appropriate name and save the created subnet sheet as a network file. Since the subnet sheet name will be maintained when it is imported later, we recommend giving it a proper subnet sheet name before exporting.

3) **Import the exported subnet sheet in the file to be connected**

In the new file, the created subnet sheet becomes a single node. Click

"Networks" -> "Import Network"

and select the exported file. The file is read as a new subnet sheet.

4) **Use it as a submodule**

Open the sheet that differ from the imported sheet. Right click on the new sheet and select the same name as that of the created subnet sheet from

"New Node" -> "Subnet".

The module represents the subnet sheet itself with the same number of inputs and outputs as those of the imported subnet sheet.

5) **Change of submodule (option)**

The imported subnet sheet can be changed as wished. See Note 2 for examples.

Sub-modularization of this large system saves time into creating the same block construct and makes it easy to see the large-scale network file. The following are usage examples of this function.

A) **Performing the same processing multiple times**

When repeating the same processing or performing parallel computations, modular processing may allow the user to use the same node repeatedly in the main sheet.

B) **Always using the processing as a template**

If, for example, the same block configuration is always used for sound source localization, it would be easier to export the sound source localization processing once as a template and read it as one node every time, rather than to explicitly describe the processing of sound source localization every time.

(Note 1) Even without the exporting and importing functions, it is okay to copy and paste all nodes of a subnet sheet. Since, however, it is troublesome to copy and paste all the nodes of a large subnet sheet, it is recommended that the nodes be exported.

(Note 2) Modifications of submodules.

5-1) **Changing the numbers of inputs and outputs and of names**

The number of inputs/outputs and the names can be changed after importing. These changes require that you also change the main sheet to connect all inputs/outputs.

5-2) **Changing parameters in a submodule one by one**

Often, when using an imported submodule multiple times, the user will want to provide an argument, allowing the parameter set in the subnet sheet to be changed each time. If so, use "subnet\_param", a property parameter type. Its usage is described in the training section material.

**Solution 2**

:Connection with other systems through a socket connection

This chapter describes how to connect HARK systems with other systems by socket communication . The current HARK can be connected to [Julius](#), a speech recognition engine, by socket communication. As a node for communication, the followings modules are in HARK by default.

- 1) SpeechRecognitionClient
- 2) SpeechRecognitionSMNClient

Using these modules, HARK clients can send feature vectors to Julius as messages through a socket, allowing Julius to process these messages. For details, see the above two sources. However, since these source codes are somewhat complicated, the following section describes simple methods of making a HARK node, both as a client and as a server.

**Solution 2-1** :Connection with other systems through a socket connection (client)

In communicating with Julius, Julius continuously listens to messages from HARK as a server program. This example can be built by creating a simple server program and a HARK node. First create the server program `listener.c`, corresponding to a system other than HARK on the Julius side.

---

```
#include <stdio.h>
#include <string.h>
#include <sys/types.h>
#include <sys/socket.h>
#include <netinet/in.h>

main(int argc, char *argv[]){

    int i;
    int fd1, fd2;
    struct sockaddr_in saddr;
    struct sockaddr_in caddr;
    int len;
    int ret;
    char buf[1024];

    if (argc != 2){
        printf("Usage:listener PORT_NUMBER\n");
        exit(1);
    }

    if ((fd1 = socket(AF_INET, SOCK_STREAM, 0)) < 0){
        perror("socket");
        exit(1);
    }

    bzero((char *)&saddr, sizeof(saddr));
    saddr.sin_family = AF_INET;
    saddr.sin_addr.s_addr = INADDR_ANY;
    saddr.sin_port = htons(atoi(argv[1]));

    if (bind(fd1, (struct sockaddr *)&saddr, sizeof(saddr)) < 0){
        perror("bind");
        exit(1);
    }

    if (listen(fd1, 1)< 0){
        perror("listen");
        exit(1);
    }

    len = sizeof(caddr);
    if ((fd2 = accept(fd1, (struct sockaddr *)&caddr, &len)< 0){
        perror("accept");
        exit(1);
    }
    close(fd1);

    ret = read(fd2, buf, 1024);

    while (strcmp(buf, "quit\n")!= 0){
        printf("Received Message :%s", buf);
        ret = read(fd2, buf, 1024);
        write(fd2, buf, 1024);
        // This returns a responce.
    }
    close(fd2);
}
```

---

The content is a simple program for normal socket communication.

This program displays a message written in `fd2`. After cutting and pasting a source, compile it.

```
> gcc -o listener listener.c
```

Next, create a client node of HARK. Cut and paste the following source to create `TalkerTutorial.cc`.

---

```

#include <iostream>
#include <BufferedNode.h>
#include <Buffer.h>
#include <string.h>
#include <sstream>
#include <stdio.h>
#include <sys/types.h>
#include <sys/socket.h>
#include <netinet/in.h>
#include <netdb.h>
#include <csignal>

using namespace std;
using namespace FD;

class TalkerTutorial;

DECLARE_NODE(TalkerTutorial);
/*Node
 *
 * @name TalkerTutorial
 * @category HARKD:Tutorial
 * @description This block outputs the same integer as PARAM1 and sends it through socket.
 *
 * @output_name OUTPUT1
 * @output_type int
 * @output_description This output the same integer as PARAM1.
 *
 * @parameter_name PARAM1
 * @parameter_type int
 * @parameter_value 123
 * @parameter_description Setting for OUTPUT1
 *
 * @parameter_name PORT
 * @parameter_type int
 * @parameter_value 8765
 * @parameter_description Port number for socket connection
 *
 * @parameter_name IP_ADDR
 * @parameter_type string
 * @parameter_value 127.0.0.1
 * @parameter_description IP address for socket connection
 *
END*/

bool exit_flag2 = false;

class TalkerTutorial : public BufferedNode {
    int output1ID;
    int param1;
    int port;
    string ip_addr;
    struct sockaddr_in addr;
    struct hostent *hp;
    int fd;
    int ret;

public:
    TalkerTutorial(string nodeName, ParameterSet params)
    : BufferedNode(nodeName, params){
        output1ID= addOutput("OUTPUT1");
        param1 =dereference_cast<int>(parameters.get("PARAM1"));
        port= dereference_cast<int>(parameters.get("PORT"));
        ip_addr = object_cast<String>(parameters.get("IP_ADDR"));
        signal(SIGINT, signal_handler);
        signal(SIGHUP, signal_handler);
        signal(SIGPIPE, signal_handler);

        if ((fd = socket(AF_INET, SOCK_STREAM, 0)) < 0){
            perror("socket");
            exit(1);
        }

        bzero((char *)&addr, sizeof(addr));
        if ((hp = gethostbyname(ip_addr.c_str()))== NULL){
            perror("No such host");
            exit(1);
        }
        bcopy(hp->h_addr, &addr.sin_addr, hp->h_length);
        addr.sin_family = AF_INET;
        addr.sin_port = htons(port);
        if (connect(fd, (struct sockaddr *)&addr, sizeof(addr)) < 0){
            perror("connect");
            exit(1);
        }
        inOrder = true;
    }

    void calculate(int output_id, int count, Buffer &out){
        // Main loop routine starts here.
        ostringstream message;
        message << "[" << count << " , " << param1 << "]" << endl;
        string buf = message.str();
        write(fd, buf.c_str(), 1024);
        cout << "Sent Message :[" << count << " , " << param1 << "]" << endl;
        (*(outputs[output1ID].buffer))[count] = ObjectRef(Int::alloc(param1));
        if(exit_flag2){
            cerr << "Operation closed..." << endl;
            close(fd);
            exit(1);
        }
    }
}

```

The content of this node also consists of a client node for simple socket communication. Socket communication is performed for character strings stored in `message` for every `count` loop. After cutting and pasting, install it from the source compilation. When a server and a client are ready, build a network of HARK . This yields a simple node that performs socket communications for every specific time cycle in `Sleep` as shown below.

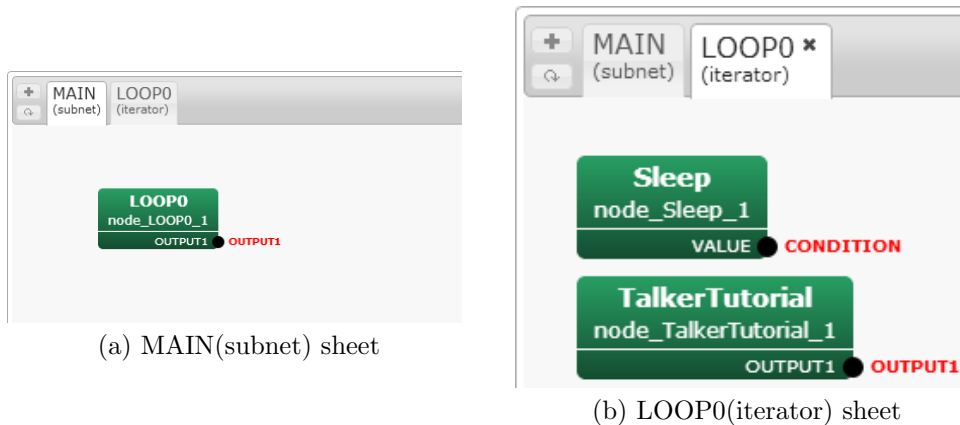

Figure 13.9: Network file : TalkerTutorial

To execute, first start the server program. Decide an appropriate port number (8765 here) and execute with the following command line.

```
> ./listener 8765
```

Next, launch the network file of HARK . Start a new console, and start the network file created in HARK-Designer above.

```
Double click the Sleep node > Set an appropriate cycle to SECONDS in float type (10000 here)
Double click the TalkerTutorial node > Set an appropriate to PARAM1 in int type
Double click the TalkerTutorial node > Set the port number to PORT in int type (8765 here)
Double click the TalkerTutorial node > Set an IP or a host name to IP_ADDR (127.0.0.1 here)
```

To set an IP address, we have assumed that both the server and the client work with the same machine. Of course, it is possible to communicate with a remote machine.

```
Click "Execute" button
```

Messages from HARK are then transferred to the operating server, where they are indicated in each console as.

Server side (listener)

```
Received Message :
[0 , 123]
Received Message :
[1 , 123]
Received Message :
[2 , 123]
...
```

Client side (HARK : TalkerTutorial)

```
Sent Message :
[0 , 123]
Sent Message :
[1 , 123]
Sent Message :
[2 , 123]
...
```

## Solution 2-1 :Connection with other systems through a socket connection (server)

Next, create a server node that can receive data from a client program by socket communication. Similar to the solution above, a simple client program is prepared, followed by the creation of a server module. First create the server program `Talker.c`, a simple client program of socket communication.

```
#include <stdio.h>
#include <string.h>
#include <sys/types.h>
#include <sys/socket.h>
#include <netinet/in.h>
#include <netdb.h>

main(int argc, char *argv[]){
    struct sockaddr_in addr;
    struct hostent *hp;
    int fd;
    int len;
    int port;
    char buf[1024];
    int ret;

    if (argc != 3){
        printf("Usage:talker SERVER_NAME PORT_NUMBER\n");
        exit(1);
    }

    if ((fd = socket(AF_INET, SOCK_STREAM, 0)) < 0){
        perror("socket");
        exit(1);
    }

    bzero((char *)&addr, sizeof(addr));

    if ((hp = gethostbyname(argv[1])) == NULL){
        perror("No such host");
        exit(1);
    }

    bcopy(hp->h_addr, &addr.sin_addr, hp->h_length);
    addr.sin_family = AF_INET;
    addr.sin_port = htons(atoi(argv[2]));
    if (connect(fd, (struct sockaddr *)&addr, sizeof(addr)) < 0){
        perror("connect");
        exit(1);
    }

    while (fgets(buf, 1024, stdin)){
        write(fd, buf, 1024);
        // ret = read(fd, buf, 1024); // This listens a response.
        // buf[ret] = '\0';
        printf("Sent Message : %s",buf);
    }
    close(fd);
    exit(0);
}
```

Clearly, character strings read on a console are sent with the descriptor named `fd`. When the file is ready, compile it as:

```
> gcc -o talker talker.c
```

In building a server node in HARK, it is important to remember that the timing of messages sent by a client is unknown, making it necessary to create a server node so that a series of processes is performed every time a message is received. Therefore, it is necessary to create a in which the server itself becomes a trigger of new loop processing. For example:

```
#include <iostream>
#include <BufferedNode.h>
#include <Buffer.h>
#include <string.h>
#include <sstream>
#include <stdio.h>
#include <sys/types.h>
#include <sys/socket.h>
#include <netinet/in.h>
#include <csignal>
```

```

using namespace std;
using namespace HARK;

class ListenerTutorial;

DECLARE_NODE(ListenerTutorial);
/*Node
 *
 * @name ListenerTutorial
 * @category HARKD:Tutorial
 * @description This block listens to messages from socket and outputs it.
 *
 * @output_name OUTPUT1
 * @output_type string
 * @output_description Same as the message received from socket.
 *
 * @output_name CONDITION
 * @output_type bool
 * @output_description True if we haven't reach the end of file yet.
 *
 * @parameter_name PORT
 * @parameter_type int
 * @parameter_value 8765
 * @parameter_description Port number for socket connection
 *
END*/

bool exit_flag = false;

class ListenerTutorial : public BufferedNode {
    int output1ID;
    int conditionID;
    int port;
    int fd1, fd2;
    struct sockaddr_in saddr;
    struct sockaddr_in caddr;
    int len;
    int ret;
    char buf[1024];

public:
    ListenerTutorial(string nodeName, ParameterSet params)
    : BufferedNode(nodeName, params){
        output1ID= addOutput("OUTPUT1");
        conditionID = addOutput("CONDITION");
        port= dereference_cast<int>(parameters.get("PORT"));
        signal(SIGINT, signal_handler);
        signal(SIGHUP, signal_handler);
        signal(SIGPIPE, signal_handler);
        if ((fd1 = socket(AF_INET, SOCK_STREAM, 0)) < 0){
            perror("socket");
            exit(1);
        }
        bzero((char *)&saddr, sizeof(saddr));
        saddr.sin_family = AF_INET;
        saddr.sin_addr.s_addr = INADDR_ANY;
        saddr.sin_port = htons(port);
        if (bind(fd1, (struct sockaddr *)&saddr, sizeof(saddr)) < 0){
            perror("bind");
            exit(1);
        }
        if (listen(fd1, 1) < 0){
            perror("listen");
            exit(1);
        }
        len = sizeof(caddr);
        if ((fd2 = accept(fd1, (struct sockaddr *)&caddr, (socklen_t *)&len)) < 0){
            perror("accept");
            exit(1);
        }
        close(fd1);
        inOrder = true;
    }

    void calculate(int output_id, int count, Buffer &out){
        // Main loop routine starts here.
        Buffer &conditionBuffer = *(outputs[conditionID].buffer);
        conditionBuffer[count]= (exit_flag ? FalseObject : TrueObject);
        ret = read(fd2, buf, 1024);
        cout << "Count :" << count << " , Received Message :" << buf << endl;
        ostream message;
        message << buf << endl;
        string output1 = message.str();
        (*(outputs[output1ID].buffer))[count] = ObjectRef(new String(output1));
    }
};

```

```

write(fd2, buf, 1024);
if(exit_flag){
    cerr << "Operation closed..." << endl;
    close(fd2);
    exit(1);
}
// Main loop routine ends here.
}

static void signal_handler(int s){
    exit_flag = true;
}
};

```

This node differs from a normal node, in that it adds a port that outputs a new bool variable named `CONDITION`. This `CONDITION` port always returns `true` except for forced terminations and pauses in socket communication. This port can trigger loops of the network file of `HARK`. After building a network file, and cutting and pasting the above source, it can be compiled and installed. `HARK-Designer` is then started, and the following node created:

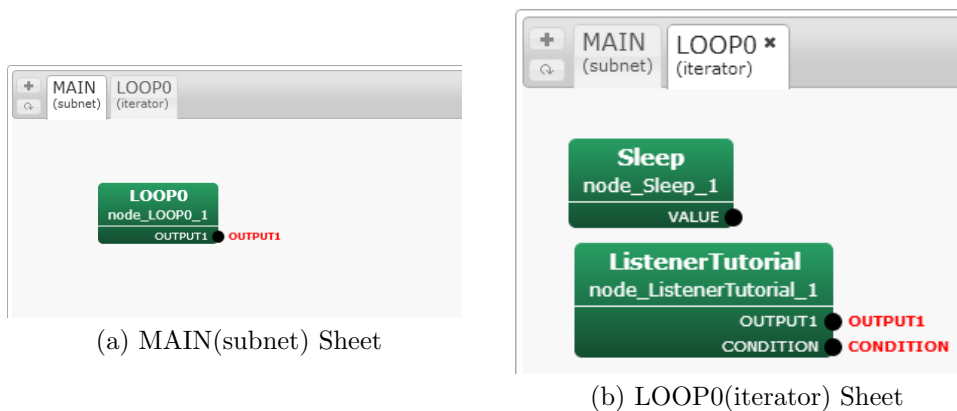

Figure 13.10: Network file: ListenerTutorial

Here, the `CONDITION` output port became `CONDITION` of a loop of the network file. That is, the loop cycle of this network file was identical to the processing cycle of `ListenerTutorial`. The `ListenerTutorial` node suspends the processing until

```
ret = read(fd2, buf, 1024);
```

receives a new message. When a message is received, all `calculate` functions are processed and the processing of one `count` is completed. Making `CONDITION` of the network file the `CONDITION` port of the `ListenerTutorial` node enables the performance of a series of processes after one receipt of messages. To execute both, the server program (network file of `HARK` created above) is started.

Double-click the `ListenerTutorial` node > Set the port number for `PORT` (8765 here)  
Click the "Execute"

Make sure to set `CONDITION`. Start the client program next. Start the new console and move to a directory that stores `talker.c`, as compiled above. Execute it using the command line.

```
> ./talker 127.0.0.1 8765
```

Assuming that the server and client work with the same machine, we have used the IP address `127.0.0.1`, although it is possible to communicate with a remote machine. Now, enter some characters into the console of `talker`. Messages from the client console will be communicated to the server node of operating `HARK`. They are indicated in each console as (e.g. when inputting "hoge1", "hoge2", "hoge3"):

Server side (`talker.c`)

```
hoge1
Sent Message :
hoge1
hoge2
Sent Message :
hoge2
hoge3
Sent Message :
hoge3
...
```

Client side (HARK : ListenerTutorial))

```
Count :
0 , Received Message :
hoge1
Count :
1 , Received Message :
hoge2
Count :
2 , Received Message :
hoge3
...
```

This way, a HARK node itself can act as a server and receive a messages from other systems.

### Solution 3

: Connection with ROS (Robot Operating System)

If your system was created in [ROS](#), the open source platform for robots developed by Willow Garage, you can create a communication between HARK and ROS using the instructions in this section.

Since a sufficient documents for ROS are available on the web, we assume here that (1) an ROS system has already been installed and, (2) the user knows the basic concepts of ROS, including publish to topic and subscribe from topic; i.e., we assume that the user has completed the Beginner Level of the [ROS tutorial](#). Since there are two connection methods, each is described here. Moreover, Python is used for implementation of the ROS node.

**(1) Use standard output** This is a method that executes HARK as a subprocess in a node, utilizing the feature that a network of HARK can be solely executed. Based on this method, localization results from HARK are output as standard outputs (when wishing to have localization results, open the DEBUG property of LocalizeMUSIC ). For example, the network `/home/hark/localize.n` can be executed in python script with the following code.

```
import subprocess
p = subprocess.Popen("/home/hark/localize.n",
                    cwd = "/home/hark/",
                    stderr = subprocess.STDOUT,
                    stdout = subprocess.PIPE)
```

Outputs of this network can be processed in python script with the code.

```
while not rospy.is_shutdown():
    line = p.stdout.readline()
    Acquire information from the line
```

The information acquired from HARK can be published to an appropriate topic.

### **(2) Use of socket communication**

Another method is to connect ROS and HARK via socket communication.

It will therefore be necessary to create a code of socket communication on the ROS side and a node on the HARK side. Despite difficulties, the entire configuration is clear for users. For creation of nodes for HARK, see the tutorial in the HARK documents. Some part of the python script, which receives information, is shown here.

```
import socket
sock = socket.socket(socket.AF_INET, socket.SOCK_STREAM) sock.bind( ('localhost', 12345)
) sock.listen(1) client, addr = sock.accept()
while 1:
received = client.recv( 1024 )
```

### **(3) Communicate through topic**

This is a communication method utilizing the ROS system. If a node to publish a message for a topic of ROS is created, localization results and separated sounds can be sent directly to ROS.

See Also

1. [ROS](#)
2. HARK document tutorial 3 (Creation of node)

## 13.4 Controlling a motor

### Problem

### Solution

Since HARK itself is software for audition processing, a module describing the control of a motor is not included. However, when performing comparatively simple control, a module can be designed to control a motor. This section describes how a method of implementing this function in the client part of HARK as a module by dividing control of a motor into applications of server and client. The following is an example of the main processing of the client module.

---

**function calculat**

1. *if count = 0 then*
2.     *set\_IP\_address\_and\_PORT\_number*
3.     *connect\_to\_server*
4. *endif*
5. *obtain\_input*
6. *generate\_control\_input*
7. *send\_control\_input*
8. *check\_motor\_state*

---

**function destructor**

1. *disconnect\_to\_server*
- 

The first calculate function performs processing related to TCP/IP connection once when it is first activated and repeats the processing for other cases. To access TCP/IP, the first activation of this function sets the assigned IP address port and connects to the server application (the second and third lines). When it is first connected to the server application, it repeats processing to generate a control command from an input. After an input is received, a command for motor control is created based on the data. This command is sent to the server application, which confirms whether the command was sent properly. The second destructor function indicates a destructor of a module and performs processing to cut off connections with the server. The server application receives a control command from the client module and drives the motor based on the command. This server application depends on motors and its description is therefore omitted here.

### Discussion

Since HARK is data flow-oriented, the presence of even one node that requires a long time for processing, makes real-time processing difficult in some cases. Therefore, processing on HARK consists of generating a command to control a motor, with the load reduced by operating the motor in other server applications. Moreover, dividing into a server and a client enables another motor to be controlled simply by changing the interface.

### See Also

For motor control, see “Creation of node” in 12.1. For the combined control of a more complicated motor or other sensors, see “Control of robot” in 12.2.

# Chapter 14

## Appendix

### 14.1 Introduction

This chapter introduces the network sample with frequent modules. Sample networks are available from [HARK wiki](#). All standard network configurations are available and therefore the network that the user wishes to create may be already registered as a sample. Therefore, it is recommended to read the category outline of sample networks. Even if there is not the desired network, it is comparatively easier to revise a sample network in the category that is close to the desired network to create the desired network. The sample networks are categorized for each function. The description is summarized simple as possible and therefore it is for training of HARK modules.

#### 14.1.1 Category of sample network

All categories of sample networks are shown in Table 14.1. There are five categories. The sample networks of each category and files required for execution of the samples are stored in the directories indicated the sample directories on the right column in the table.

For execution of a sample network, execute a script corresponding to each network file name. Set values of arguments to be given to the network file and necessary setting files are described. For example, when you want to use a script file named demo.n, execute the following files:

For Ubuntu

The script name is “demo.sh.”

For Windows

The batchfile is “demo.bat.”

Character strings before ”.” are commonized. However, demo.sh may include the setting items that depend on operating environments (i.e. IP address) and therefore unexpected result may occur when executing without confirmation. The correct setting method is described in description of each sample network.

Table 14.1: Sample network category

	Category name	Sample directory name
1	Sound recording network	Record
2	Sound source localization network	Localize
3	Sound source separation network	Separation
4	Acoustic feature extraction network	FeatureExtraction
5	Speech recognition network	Recognition

Indicate below outline of category of each sample.

- **Sound recording network**

This is a sample for which modules of the AudioIO category of HARK are used. Monaural sound recording and stereophonic recording are included as basic sound recording samples. Stereophonic recording and monaural sound recording operate in most hardware environments.

- **Sound source localization network**

This is a sample for which modules of the Localization category of HARK are used. This is a sample in particular for usage of LocalizeMUSIC. A sample in which a sound source localization result is

displayed on a screen with `DisplayLocalization` and saved in a file with `SaveSourceLocation` is available. Recorded sounds for eight channels is available so that sound source localization processing can be confirmed off-line/ Since it is off-line processing, AD/DA is not required and therefore any computers can operate if HARK is already installed. In order to execute online localization processing, AD/DA for the multi-channel recording that HARK supports is required.

- **Sound source separation network**

This is a sample for which modules of the Separation category of HARK are used. This is a sample in particular for usage of `GHDSS` and `PostFilter` or `GHDSS` and `HRLE`. A sample in which off-line sound source localization processing is performed to recorded sounds for eight channels is available. Since it is off-line processing, AD/DA is not required and therefore any computers can operate if HARK is already installed. In order to execute online localization processing, AD/DA for the multi-channel recording that HARK supports is required.

- **Acoustic feature extract network**

This is a sample in which modules of the FeatureExtraction category of HARK are used. This is a sample in particular for usage of `MSLSExtraction` and `MFCCExtraction`. A sample in which off-line acoustic feature extract is performed to recorded sounds for one channel is available.

- **Speech recognition network**

This is a sample in which ASR of HARK and modules of the MFM category are used. This is a sample in particular for usage of `MFMGeneration` and `SpeechRecognitionClient`. A sample in which off-line sound source localization processing is performed to recorded sounds for eight channels is available.

### 14.1.2 Notation of document and method for execution of sample network

An operation example of the description is shown in the rectangular region. `>` on the line head indicates a command prompt. The part of the operation example indicates an input from the user, and the second line indicates a message from the system. In the following example, `"!"` in the first line indicates a command prompt. Note that the prompt is displayed in different ways (e.g. `"%"`, `"$"`) according to operating

```
> echo Hello World!  
Hello World!
```

Figure 14.1: Execution example of sample network start-up script

environments. The letters that come after the prompt in the first line are the letters entered by the user. In the above example, the seventeen letters of `echo "HelloWorld!"` are the letters entered by the user. Press the enter key at the end of line. The letters in the second line are the output from the system, which are displayed as pressing the enter key at the end of the first line.

## 14.2 Sound recording network sample

When you record signals using a device, you can use sample network files included in the RecordLin and RecordWin folders. We explain samples for Ubuntu in Section 14.2.1 and for Windows in Section 14.2.2, respectively.

### 14.2.1 Ubuntu

Four kinds of sound recording network samples are available as shown in Table 14.2. The left column indicates network files and the right column indicates processing contents.

Table 14.2: Sound recording network list.

Network file name	Processing content
demoALSA.n	ALSA sound recording
demoWS.8ch.n	Sound recording for eight channels with RASP
demoRASP24.8ch.n	Sound recording for eight channels with RASP24

For ALSA devices, you can use a shell script demoALSA.sh for recording various number of frames, number of channels, and device names. For example, if you want to record 200 frames from an 2-ch audio device whose name is plughw:1,0, you can use this script as shown below:

```
> ./demoALSA.sh 200 2 plughw:1,0
UINodeRepository::Scan()
Scanning def /usr/lib/flowdesigner/toolbox
done loading def files
loading XML document from memory
done!
Building network :MAIN
<Bool 1 >
```

Figure 14.2: Execution example of demoALSA.sh.

Note that the difference between these networks is only the parameters of AudioStreamFromMic module. The DEVICE parameter (plughw:1,0, 127.0.0.1, etc.) changes according to an environment. Therefore, an user has to set correct value.

A sample network consists of two sub-networks (MAIN, MAIN\_LOOP). MAIN (subnet) and MAIN\_LOOP (iterator) have one and six modules, separately. Figure 14.3 and 14.4 shows MAIN (subnet) and MAIN\_LOOP (iterator). It is simple network configuration in which the audio waveforms collected in the AudioStreamFromMic module are selected in ChannelSelector, and written in files in SaveWavePCM. The SaveWavePCM module connected to OUTPUT1 saves a file with eight channel signal. The other SaveWavePCM module saves eight files with each channel signal.

Iterate is a module that indicates that the execution is repeated for the number of times set by the user. Designate the number of frames to be collected and adjust sound recording time.

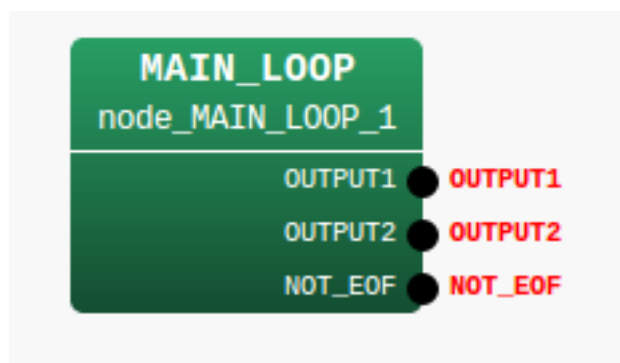

Figure 14.3: MAIN (subnet)

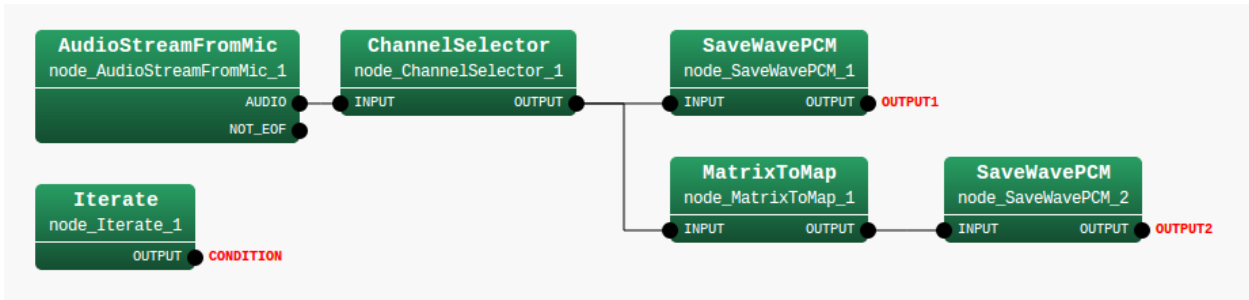

Figure 14.4: MAIN\_LOOP (iterator)

There are five properties for the MAIN\_LOOP node in MAIN (subnet). Table 14.3 shows a list of them. SAMPLING\_RATE and GET\_FRAMES are important. Each parameter value is set according to the values in the table. Set value of GET\_FRAMES is `int :ARG1` here. This means the monobasic argument of `demoALSA_2ch.n` casted to the integral type and substituted. The number of sound recording frames is given to this argument in `demoALSA_2ch.n` in `demoALSA_2ch.sh`. Designate sound recording time length as the number of frames acquired and the actual sound recording time length is expressed in sec as follows.

$$(LENGTH + (GET\_FRAMES - 1) * ADVANCE) / SAMPLING\_RATE \quad (14.1)$$

Table 14.3: Parameter list of MAIN\_LOOP

Parameter name	Type	Set value	Unit	Description
ADVANCE	int	160	[pt]	Shift Length
LENGTH	int	512	[pt]	FFT length
SAMPLING_RATE	int	16000	[Hz]	Sampling frequency
GET_FRAMES	subnet_param	int :ARG1		Number of frames for sound recording
DOWHILE	bool			Blank

### Stereo recording with ALSA-based devices

Execute `demoALSA_2ch.sh` in the Record directory. After the execution, one stereo file `rec_all_0.wav` and two monaural files `rec_each_0.wav`, `rec_each_1.wav` are generated. When replaying these files, the recorded content can be confirmed.

Some computer rarely do not accept stereo recording so an error may occur. In the case that the sound recording cannot be performed well even though the computer is able to accept stereo recording, confirm the check items for monaural sound recording. Five nodes are included in this sample. There is one node in MAIN (subnet) and are four nodes in MAIN\_LOOP (iterator). It is simple network configuration in which the audio waveforms collected in the `AudioStreamFromMic` module are written in a file in `SaveWavePCM`. Data formats between nodes are uniformed through `MatrixToMap`. `Iterate` is a node that indicates that the execution is repeated for the number of times set by the user. Designate the number of frames to be collected and adjust sound recording time. What is different from the monaural sound recording network is the only `CHANNEL_COUNT` property of the `AudioStreamFromMic` node. It is 1 for monaural recording and 2 for stereo recording.

Recording cannot be performed well, perform the following checks.

1. Confirm if the sound is replayed or recorded with software other than HARK. If the sound cannot be replayed or recorded, the OS and driver, and audio interface may not be properly set or connected so check them.
2. The microphones are properly connected. Confirm if the plugs are not unplugged or loosened and connect them properly.
3. Check if the microphone terminals of the computer accept plug in power. If they do not accept plug in power, it is necessary to supply a power to the microphones. For battery type microphones, set batteries and switch on. For battery box type microphones, connect battery boxes and switch on.
4. When more than two audio interfaces are connected, remove audio interfaces after the second ones before recording the sound. If recording cannot be performed with one audio interface, change the property of `demo.n`. For the `DEVICE` property of the `AudioStreamFromMic` module, try setting of 0,0 plughw: 0,1 plughw: 0,2.

Parameters of `AudioStreamFromMic` are shown in Table 14.4. In this node, designate a sound recording device. Designate a sound recording device in this node. In this demo, the number of sound recording channels is 2ch so that a lot of users can check the operation, and ALSA is designated for `DEVICETYPE` and `plughw:0,0` is designated for `DEVICE`.

Table 14.4: Parameter list of `AudioStreamFromMic`

Parameter name	type	Set value	Unit	Description
LENGTH	subnet_param	LENGTH	[pt]	FFT length
ADVANCE	subnet_param	ADVANCE	[pt]	Shift length
CHANNEL_COUNT	int	2	[ch]	Number of sound recording channel
SAMPLING_RATE	subnet_param	16000	[Hz]	Sampling frequency
DEVICETYPE	string	ALSA		Device type
DEVICE	string	plughw:0,0		Device name

### 8ch sound recording with radio RASP

Execute `demoWS.8ch.sh` in a Record directory, after setting several items. Although 127.0.0.1 is designated as an IP address of the radio RASP in `demoWS.8ch.n`, it is necessary to change this to an appropriate IP address. If configuration of `FPAA` for the radio RASP is not completed yet, complete it here. See the document of radio RASP for the method to execute `ws_fpaa.config`. After the execution, one file `rec_all_0.wav` and eight monaural files `rec_each_0.wav`, `rec_each_1.wav`, ..., `rec_each_7.wav` are generated. When replaying these files, the recorded content can be confirmed.

When recording cannot be performed well, perform the following checks.

1. Check if the microphones are properly connected. Check if the plugs are not unplugged or loosened and connect them properly.
2. The network connection is established with the IP address of RASP. Check the network connection with ping.
3. A correct IP address of RASP is set to `AudioStreamFromMic`.
4. Initialization of `FPAA` of RASP is completed.
5. Confirm if the sound is replayed or recorded with software other than HARK. If the sound cannot be replayed or recorded, the OS and driver, and audio interface may not be properly set or connected so check them.

Parameters of `AudioStreamFromMic` are shown in Table 14.5. Designate a sound recording device in this node. Designate a multi-channel sound recording device. Set 16ch to the number of sound recording channel, designate `WS`, which indicates radio RASP, in `DEVICETYPE` and an IP address in `DEVICE`. In order to execute the sample, it is necessary to change the address to that of the actual radio RASP.

Note that when `WS` is used, `CHANNEL_COUNT` must be 16. Therefore, when a user want to record eight channel sound with `WS`, use `ChannelSelector` to select eight channels from 16 channels. In this sample, from 0 to 7 channels are selected.

Table 14.5: Parameter list of `AudioStreamFromMic`

Parameter Name	Type	set value	Unit	Description
LENGTH	subnet_param	LENGTH	[pt]	FFT length
ADVANCE	subnet_param	ADVANCE	[pt]	Shift length
CHANNEL_COUNT	int	16	[ch]	Number of channels for sound recording
SAMPLING_RATE	subnet_param	16000	[Hz]	Sampling frequency
DEVICETYPE	string	WS		Device type
DEVICE	string	127.0.0.1		Device name

### 8ch sound recording with RASP24

Execute `demoRASP24_8ch.n` in the Record directory. After the execution, one file `rec_all_0.wav` and eight monaural files `rec_each_0.wav`, `rec_each_1.wav`, ..., `rec_each_7.wav` are generated. When replaying these files, the recorded content can be confirmed.

When recording cannot be performed well, perform the following checks.

1. Check if the microphones are properly connected. Check if the plugs are not unplugged or loosened and connect them properly.

2. The network connection is established with the IP address of RASP24. Check the network connection with ping.
3. A correct IP address of RASP24 is set to `AudioStreamFromMic` .
4. Confirm if the sound is replayed or recorded with software other than HARK. If the sound cannot be replayed or recorded, the OS and driver, and audio interface may not be properly set or connected so check them.

Parameters of `AudioStreamFromMic` are shown in Table 14.6. RASP24 can record sound with 16 bit or 32 bit. When perform 16 bit and 32 bit recording, use RASP24-16 and RASP24-32, separately. Designate a sound recording device in this node. Designate a multi-channel sound recording device. Set 16ch to the number of sound recording channel and IP address in `DEVICE`. In order to execute the sample, it is necessary to change the address to that of the actual radio RASP24.

Note that a parameter `GAIN` is added when RASP24 is used as shown in Figure 14.5.

Table 14.6: Parameter list of `AudioStreamFromMic`

Parameter name	type	Set value	Unit	Description
<code>LENGTH</code>	<code>subnet_param</code>	<code>LENGTH</code>	[pt]	FFT length
<code>ADVANCE</code>	<code>subnet_param</code>	<code>ADVANCE</code>	[pt]	Shift length
<code>CHANNEL_COUNT</code>	<code>int</code>	16	[ch]	Number of sound recording channel
<code>SAMPLING_RATE</code>	<code>subnet_param</code>	16000	[Hz]	Sampling frequency
<code>DEVICETYPE</code>	<code>string</code>	RASP24-16		Device type
<code>GAIN</code>	<code>string</code>	0dB		<code>GAIN</code>
<code>DEVICE</code>	<code>string</code>	127.0.0.1		Device name

When a user set `GAIN` parameter, be careful about clipping.

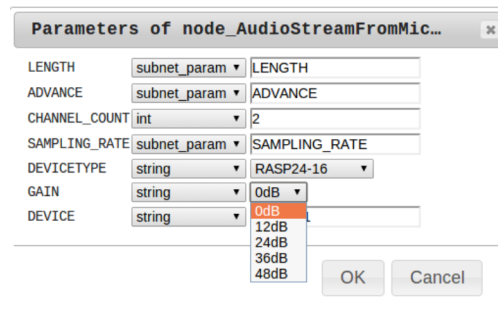

Figure 14.5: Additional parameter for RASP24

## 14.2.2 Windows

### 4ch Sound Recording with DS-based devices

Execute `demoDS_4ch.sh` in the `RecordWin` directory. After the execution, one 4ch file `rec.all_0.wav` and two monaural files `rec.each_0.wav`, `rec.each_1.wav` are generated. When replaying these files, the recorded content can be confirmed.

Recording cannot be performed well, perform the following checks.

1. Confirm if the sound is replayed or recorded with software other than HARK. If the sound cannot be replayed or recorded, the OS and driver, and audio interface may not be properly set or connected so check them.
2. The microphones are properly connected. Confirm if the plugs are not unplugged or loosened and connect them properly.
3. Check if the microphone terminals of the computer accept plug in power. If they do not accept plug in power, it is necessary to supply a power to the microphones. For battery type microphones, set batteries and switch on. For battery box type microphones, connect battery boxes and switch on.
4. When more than two audio interfaces are connected, remove audio interfaces after the second ones before recording the sound.

5. When you use Kinect, you must install a drive in advance.

Parameters of `AudioStreamFromMic` are shown in Table 14.7. In this node, designate a sound recording device. Designate a sound recording device in this node. In this demo, the number of sound recording channels is 4ch so that a lot of users can check the operation, and DS is designated for `DEVICETYPE` and Kinect is designated for `DEVICE`.

Table 14.7: Parameter list of `AudioStreamFromMic`

Parameter name	type	Set value	Unit	Description
LENGTH	subnet_param	LENGTH	[pt]	FFT length
ADVANCE	subnet_param	ADVANCE	[pt]	Shift length
CHANNEL_COUNT	int	4	[ch]	Number of sound recording channel
SAMPLING_RATE	subnet_param	16000	[Hz]	Sampling frequency
DEVICETYPE	string	DS		Device type
DEVICE	string	Kinect		Device name

### 8ch sound recording with RASP24

Execute `demoRASP24_8ch.n` in the `RecordLin` directory. After the execution, one file `rec_all_0.wav` and eight monaural files `rec_each_0.wav`, `rec_each_1.wav`, ..., `rec_each_7.wav` are generated. When replaying these files, the recorded content can be confirmed.

When recording cannot be performed well, perform the following checks.

1. Check if the microphones are properly connected. Check if the plugs are not unplugged or loosened and connect them properly.
2. The network connection is established with the IP address of RASP24. Check the network connection with ping.
3. A correct IP address of RASP24 is set to `AudioStreamFromMic` .
4. Confirm if the sound is replayed or recorded with software other than HARK. If the sound cannot be replayed or recorded, the OS and driver, and audio interface may not be properly set or connected so check them.

Parameters of `AudioStreamFromMic` are shown in Table 14.6.

## 14.3 Network sample of sound source localization

We provide two network sample files for sound source localization. You can execute all network files using `demo.sh`. Table 14.8 show the network file name, how to run it, and the description.

Table 14.8: Sound source localization network list.

Network file name	Execution	Content
demoOffline.n	demo.sh offline	Sound source localization of 4ch audio file
demoOnline.n	demo.sh online	Online sound source localization using Kinect

### 14.3.1 Offline sound source localization

#### Execution

Run the offline localization in Localization directory. This script displays the sound source localization result of three 4ch audio file that includes simultaneous speech of two speakers from -30 and 30 degrees (`MultiSpeech.wav`). You can find the file in data directory.

You can run the script by

```
> ./demo.sh offline
```

Then, you will see the output like Figure 14.6 in the terminal, and a graph of sound source localization.

```
UINodeRepository::Scan()
Scanning def /usr/lib/flowdesigner/toolbox
done loading def files
loading XML document from memory
done!
Building network :MAIN
TF was loaded by libharkio2.
1 heights, 72 directions, 1 ranges, 7 microphones, 512 points
Source 0 is created.
(skipped)
Source 5 is removed.
UINodeRepository::Scan()
(skipped)
```

Figure 14.6: Result of offline localization

#### Checking the results

After you ran the script, you will find two text files: `Localization.txt` and `log.txt`. If you cannot find them, you failed the execution. Check the following things:

1. Check if `MultiSpeech.wav` is in the `../data` directory. These files are real recorded sound by Kinect, which is supported by HARK. You cannot run the network since this is the input file.
2. Check if the `kinect_loc.zip` file is in the `../config` directory. They are the transfer function file for localization. See `LocalizeMUSIC` for details.

`Localization.txt` contains sound source localization results generated by `SaveSourceLocation` in a text format. They contain the frame number and sound source direction for each frame. You can load them using `LoadSourceLocation`. See HARK document for the format of the file.

`log.txt` contains the MUSIC spectrum generated by `LocalizeMUSIC` with `DEBUG` property `true`. MUSIC spectrum means a kind of confidence of the sound existence, calculated for each time and direction. The sound exists if the MUSIC spectrum value is high. See `LocalizeMUSIC` in HARK document for details. We also provide the visualization program of MUSIC spectrum. Run the following commands:

```
> python plotMusicSpec.py log.txt
```

If you fail, your system may not have necessary python package. Run the following command:

— For Ubuntu —

```
sudo apt-get install python python-matplotlib
```

This result can be used for tuning the `THRESH` property of `SourceTracker`.

### Sample network description

This sample has nine nodes. Three nodes are in MAIN (subnet) and six nodes are in MAIN\_LOOP (iterator). MAIN (subnet) and MAIN\_LOOP (iterator) are shown in Figures 14.7 and 14.8. `AudioStreamFromWave` loads the waveform, `MultiFFT` transforms it to spectrum, `LocalizeMUSIC` localizes the sound, `SourceTracker` tracks the localization result, then, `DisplayLocalization` shows them and `SaveSourceLocation` stores as a file.

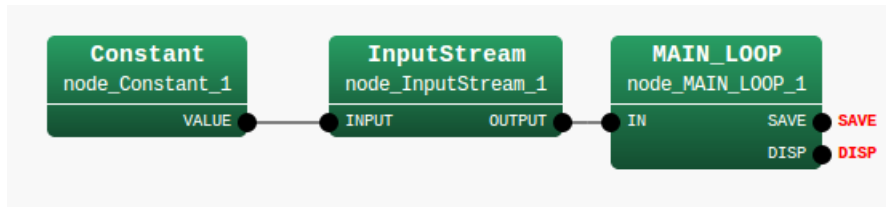

Figure 14.7: MAIN (subnet)

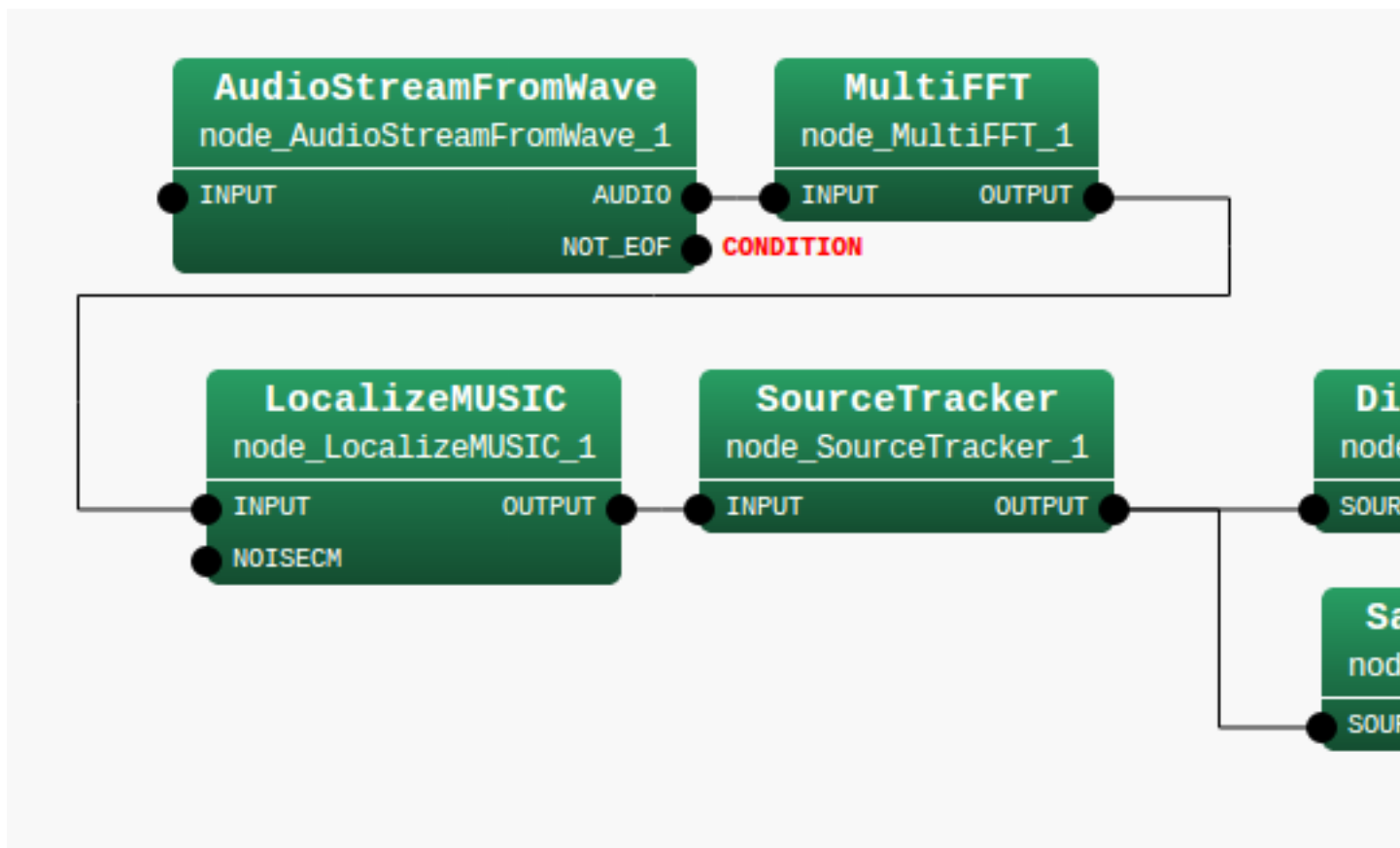

Figure 14.8: MAIN\_LOOP (iterator)

Table 14.9 summarizes the main parameters. The most important parameter is `A_MATRIX`, which specifies a file name of transfer function for localization. If you use a microphone array we support, you can download them from HARK web page. However, if you want use your own microphone array, you need to make it by harktool.

### 14.3.2 Online sound source localization

#### Execution

First, connect your Kinect to a USB port of your computer. Then, run the following command:

Table 14.9: Parameter list

Node name	Parameter name	Type	Value
MAIN_LOOP	LENGTH	int	512
	ADVANCE	int	160
	SAMPLING_RATE	int	16000
	A_MATRIX	int	ARG2
	FILENAME	subnet_param	ARG3
	DOWHILE	bool	(empty)
LocalizeMUSIC	NUM_CHANNELS	int	4
	LENGTH	subnet_param	LENGTH
	SAMPLING_RATE	subnet_param	SAMPLING_RATE
	A_MATRIX	subnet_param	A_MATRIX
	PERIOD	int	50
	NUM_SOURCE	int	1
	MIN_DEG	int	-90
	MAX_DEG	int	90
	LOWER_BOUND_FREQUENCY	int	300
	HIGHER_BOUND_FREQUENCY	int	2700
	DEBUG	bool	false

```
> cat /proc/asound/cards
0 [AudioPCI      ]: ENS1371 - Ensoniq AudioPCI
                        Ensoniq AudioPCI ENS1371 at 0x2080, irq 16
1 [Audio         ]: USB-Audio - Kinect for Windows USB Audio
                        Microsoft Kinect for Windows USB Audio at usb-0000:02:03.0-1, high speed
```

If you see the word “Kinect”, the OS successfully recognized it. In this case, its device name is `plughw:1` because the number shown in the left side of “Kinect” is one. If the number is not `plughw:1`, open `demo.sh` and edit `DEVICE`.

Then, run the script

```
> ./demo.sh online
```

You will see the result like Figure 14.9 in your terminal, and visualized sound locations.

```
UINodeRepository::Scan()
Scanning def /usr/lib/flowdesigner/toolbox
done loading def files
loading XML document from memory
done!
Building network :MAIN
TF was loaded by libharkio2.
1 heights, 72 directions , 1 ranges , 7 microphones , 512 points
Source 0 is created.
Source 0 is removed.
(skipped)
```

Figure 14.9: Execution example of online sound source localization

## Checking the result

If you have problem on localization, check the same things as offline localization. You can also refer to the recipe: [Localization failed](#).

## Sample network description

Seven nodes are included in this sample. There is one node in MAIN (subnet) and are six nodes in MAIN\_LOOP (iterator). MAIN (subnet) and MAIN\_LOOP (iterator) are shown in Figures ?? and 14.11. `AudioStreamFromMic` records the sound. `SaveWavePCM` stores the sound. Simultaneously, `MultiFFT` transforms it to spectral representation, `LocalizeMUSIC` localizes it for each frame, `SourceTracker` tracks using temporal connectivity, and `DisplayLocalization` displays it.

Table 14.10 summarizes the main parameters.



Figure 14.10: MAIN (subnet)

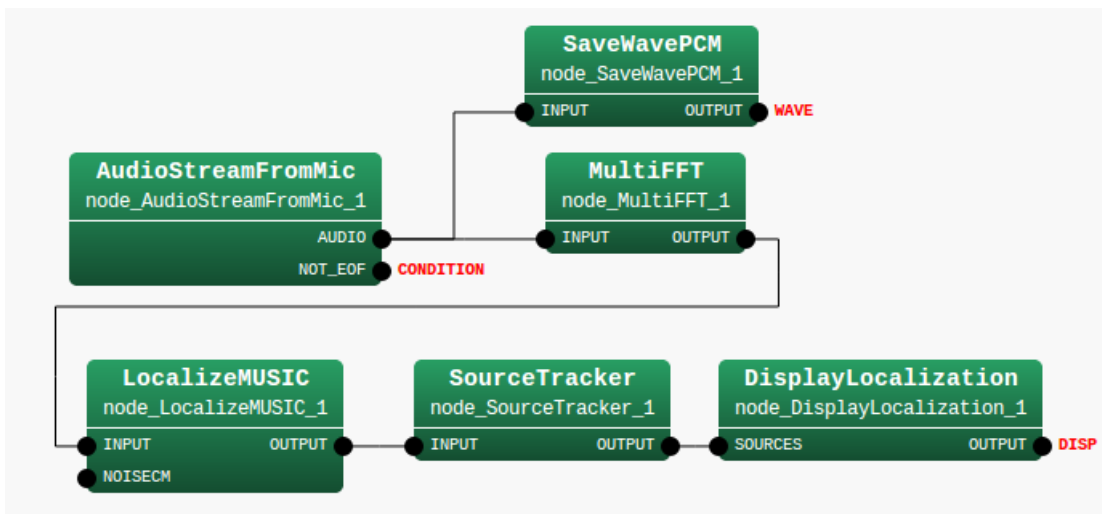

Figure 14.11: MAIN\_LOOP (iterator)

Table 14.10: Parameter list

Node name	Parameter name	Type	Value
MAIN_LOOP	LENGTH	int	512
	ADVANCE	int	160
	SAMPLING_RATE	int	16000
	A_MATRIX	string	ARG1
	DOWHILE	bool	(empty)
LocalizeMUSIC	NUM_CHANNELS	int	4
	LENGTH	subnet_param	LENGTH
	SAMPLING_RATE	subnet_param	SAMPRING_RATE
	A_MATRIX	subnet_param	A_MATRIX
	PERIOD	int	50
	NUM_SOURCE	int	1
	MIN_DEG	int	-90
	MAX_DEG	int	90
	LOWER_BOUND_FREQUENCY	int	300
	HIGHER_BOUND_FREQUENCY	int	2700
DEBUG	bool	false	

## 14.4 Network sample of sound source separation

There are four kinds of network samples for sound source separation as shown in Table 14.11. The left column indicates network files, the middle column indicates shell script files to operate the networks and the right column indicates processing contents.

You can run these samples using `demo.sh` as follows.

```
> ./demo.sh offline # Offline processing without HRLE
> ./demo.sh offline HRLE # Offline processing with HRLE
> ./demo.sh online # Online processing without HRLE
> ./demo.sh online HRLE # Online processing with HRLE
```

Table 14.11: Sound source separation network list.

Network file name	Network execution script	Processing content
demoOffline.n demoOfflineHRLE.n	demoOffline.sh demoOfflineHRLE.sh	Sound source separation of 4ch audio Processing for which noise estimation by HRLE as a postprocessing
demoOnline.n demoOnlineHRLE.n	demoOnline.sh demoOnlineHRLE.sh	Sound source separation of captured audio Processing for which noise estimation by HRLE as a postprocessing

### 14.4.1 Off line sound source separation

A sample of off line sound source separation is introduced first. Since input sounds are files, even the users who do not have a multi-channel AD can confirm while executing sound source separation.

Run `demo.sh` in Separation directory with a command line argument “offline”. After you run, you will see the separated sounds in `sep_files/`. The file names are `offline_%d.wav`.

If you failed run the sample, check the following things.

1. Check if the transfer function files `kinect_loc.zip`, `kinect_sep.zip` files are in the `../config` directory.
2. Check if `MultiSpeech.wav` is in the `../data` directory.

Twelve nodes are included in this sample. There are three nodes in MAIN (subnet) and are nine nodes in MAIN\_LOOP (iterator). MAIN (subnet) includes `Constant`, `InputStream`, and `MAIN_LOOP` (iterator). `MAIN_LOOP` (iterator) is shown in Fig. 14.12 The audio waveforms read from the files in the `AudioStreamFromWave` node are analyzed in `MultiFFT`, separated in `GHDSS`, synthesized in `Synthesize` and the audio waveforms are saved in `SaveWavePCM`.

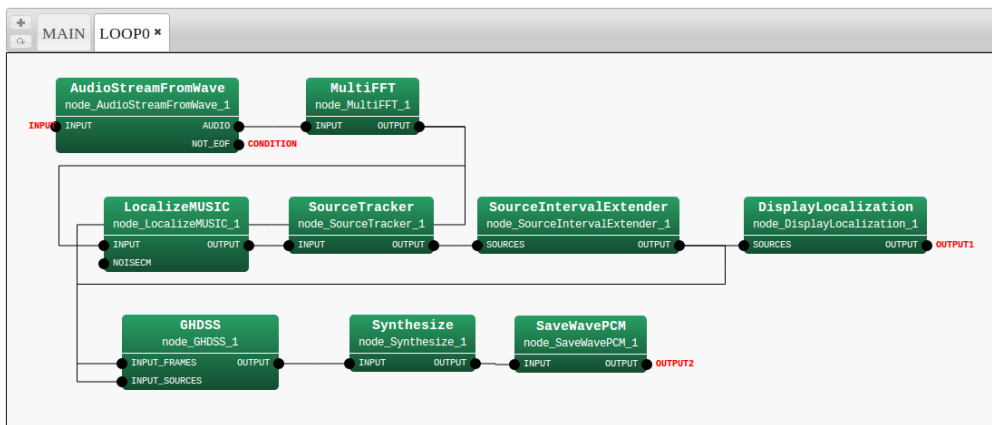

Figure 14.12: Sound source separation without HRLE

An important parameter is `TF_CONJ_FILENAME`. Use the file created in `harktool3` from impulse responses of a kinect.

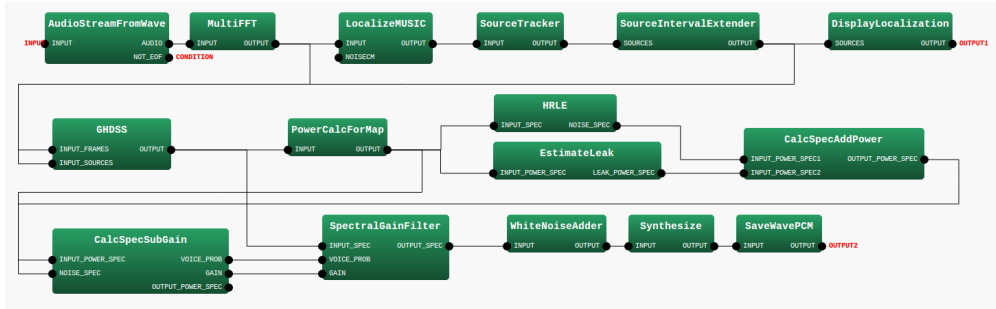

Figure 14.13: MAIN\_LOOP (iterator)

### 14.4.2 Off-line sound source separation (with postprocessing by HRLE)

A sample network file that separates sound by GHDSS node and post process for speech enhancement using HRLE is introduced here.

Run the demo.sh with commandline arguments `offline` and `HRLE`. Then, you will find the separated files in `sep_files/` directory. The file name is `offlineHRLE_%d.wav`

Figure 14.13 shows sample network of `demoOfflineHRLE.n`, which is off-line sound source separation with postprocessing by HRLE. The audio waveforms read from the files in the `AudioStreamFromWave` node are analyzed in `MultiFFT`, separated in `GHDSS`, postprocessed, synthesized in `Synthesize` and the audio waveforms are saved in `SaveWavePCM`. The postprocessing is realized by combinations of `HRLE`, `EstimateLeak`, `CalcSpecAddPower`, `CalcSpecSubGain` and `SpectralGainFilter`. Interference from a non-purpose sound is estimated from nondirectional noise and the sound sources detected and spectral levels for each band are adjusted.

### 14.4.3 Online sound source separation (with/without postprocessing by HRLE)

Samples of online sound source separation are introduced here. You need Kinect for these samples.

If you want to run with HRLE post processing, run `demo.sh` with command line arguments `online` and `HRLE`. If you want to run without HRLE, run `demo.sh` with a command line argument `online`.

If you successfully finished running, you will find the graphical localization results and the separated files in `sep_files/` directory. The file names are `online_%d.wav` and `onlineHRLE_%d.wav`. You can stop by pressing the Control key and 'c' key at the same time.

If you failed running, check the network or device using chapter 3.

## 14.5 Network samples of Feature extraction

### 14.5.1 Introduction

HARK provides static feature extraction modules such as `MSLSExtraction` and `MFCCExtraction`. HARK also provides following additional feature extraction modules and preprocessing modules:

1. Dynamic feature (Delta term): The temporal change of the static features. Notated as  $\Delta$ MSLS in Tab. 14.12. Calculated by `Delta`.
2. Power: The power of the input signal. Notated as Power in Tab. 14.12. Calculated by `PowerCalcForMap`.
3. Delta power: The temporal change of power. Notated as  $\Delta$ Power in Tab. 14.12. Calculated by `Delta`.
4. Preprocessing: Emphasizing of the high frequency range using `PreEmphasis` or mean normalization. Notated as Preprocessing in Tab. 14.12.

We provide six sample networks of acoustic feature extraction as shown in Tab. 14.12. From the left, the three columns of the table denotes: the network file name, the feature description, and the feature file name generated by the network file. You can run the samples by executing `demo.sh`. For example, if you want to execute `demo1.n`, run

```
> ./demo.sh 1
```

The samples calculate the features using the MSLS of 13 dimensions in offline. If you want to calculate features in online, replace `AudioStreamFromWave` with `AudioStreamFromMic`. If you want to use MFCC instead of MSLS, replace `MSLSExtraction` with `MFCCExtraction`. If you want to change the dimension of the MSLS, change the property. See HARK document for details.

Table 14.12: Sample files of feature extraction

Network file name	Feature						Generated file
	MSLS 13 dim	$\Delta$ MSLS 13 dim	Power 1 dim	$\Delta$ Power 1 dim	Preprocessing no dim	Corresponding section	
demo1.n	Yes					<a href="#">14.5.2</a>	MFBANK13_0.spec
demo2.n	Yes	Yes				<a href="#">14.5.3</a>	MFBANK26_0.spec
demo3.n	Yes		Yes			<a href="#">14.5.4</a>	MFBANK14_0.spec
demo4.n	Yes	Yes	Yes	Yes		<a href="#">14.5.5</a>	MFBANK28_0.spec
demo5.n	Yes	Yes		Yes		<a href="#">14.5.6</a>	MFBANK27_0.spec
demo6.n	Yes	Yes		Yes	Yes	<a href="#">14.5.7</a>	MFBANK27p_0.spec

### 14.5.2 MSLS

An execution example is shown in Figure 14.14. After the execution, a file named `MFBANK13_0.spec` is generated. This file stores little endian 13 dimensional vector sequence expressed in the 32 bit floating-point number format. When separation cannot be performed well, check if the `f101b001.wav` files are in the data directory.

```
> ./demo.sh 1
MSLS
UINodeRepository::Scan()
Scanning def /usr/lib/flowdesigner/toolbox
done loading def files
loading XML document from memory
done!
Building network :MAIN
```

Figure 14.14: Execution example

Twelve modules are included in this sample. There are three modules in `MAIN_LOOP` (iterator) and nine modules in `MAIN` (subnet). `MAIN` (subnet) and `MAIN_LOOP` (iterator) are shown in Figure 14.15 and Figure 14.16. As an outline of the processing, it is simple network configuration in which acoustic features are calculated in `MSLSExtraction` with the audio waveforms collected in the `AudioStreamFromWave` module and are written in `SaveFeatures`. Since `MSLSExtraction` requires the outputs of the mel-scale filter bank and power spectra for calculation of MSLS, the collected audio waveforms are analyzed by `MultiFFT` and their

data type are converted by MatrixToMap and PowerCalcForMap , and then processing to obtain outputs of the mel-scale filter bank is performed by MelFilterBank . MSLSExtraction reserves a storing region for the  $\delta$  MSLS coefficient other than the MSLS coefficient and outputs vectors that are double of the values specified in the FBANK\_COUNT property of MSLSExtraction as a feature (zero is in the storing region for the  $\delta$  MSLS coefficient). Therefore, it is necessary to delete the  $\delta$  MSLS coefficient domain, which is unnecessary here. Use FeatureRemover to delete it. SaveFeatures saves the input FEATURE. The localization result from the front generated by ConstantLocalization is gave to SOURCES.

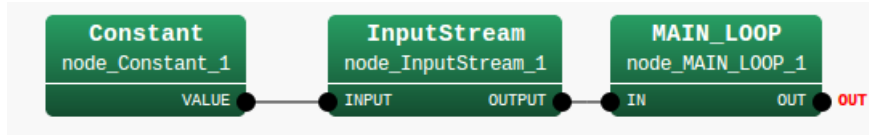

Figure 14.15: MAIN (subnet)

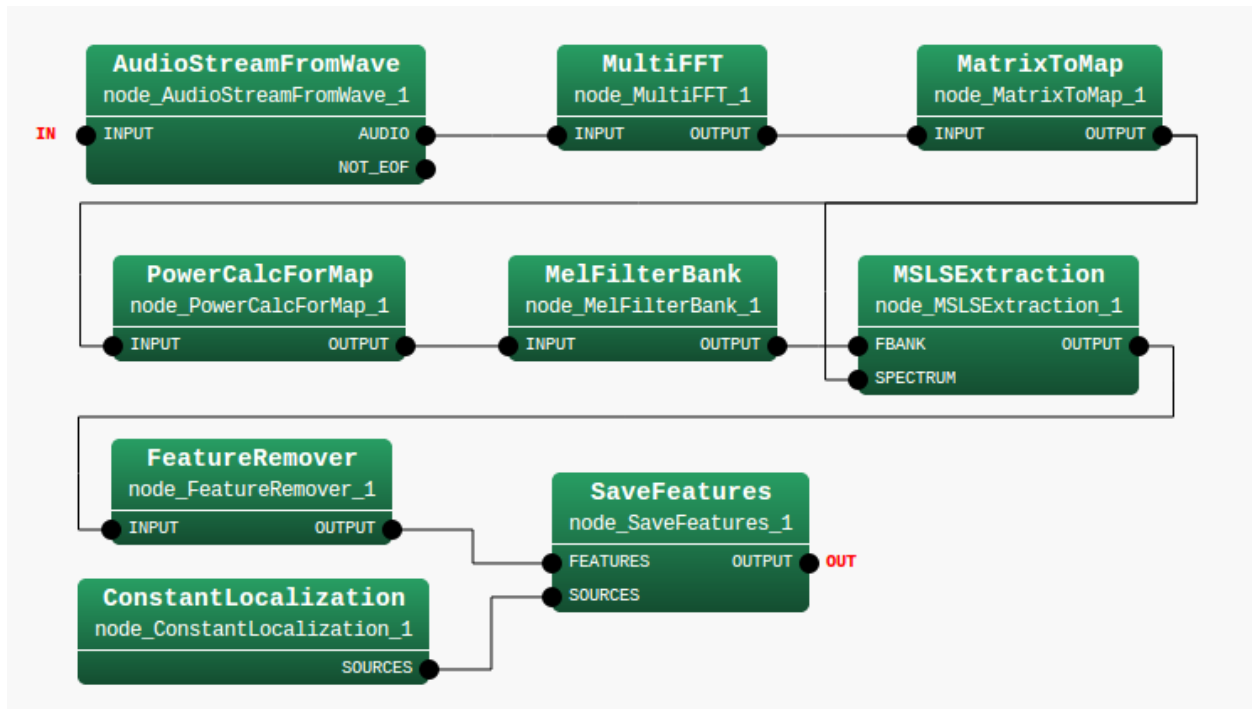

Figure 14.16: MAIN\_LOOP (iterator)

Table 14.13 summarizes the main modules. The most important module is MSLSExtraction .

Table 14.13: Parameter list

Node name	Parameter name	Type	Value
MAIN_LOOP	LENGTH	subnet_param	int :ARG2
	ADVANCE	subnet_param	int :ARG3
	SAMPLING_RATE	subnet_param	int :ARG4
	FBANK_COUNT	subnet_param	int :ARG5
	DOWHILE	bool	(empty)
MSLSExtraction	FBANK_COUNT	subnet_param	FBANK_COUNT
	NORMALIZE_MODE	string	Cepstral
	USE_POWER	bool	false

### 14.5.3 MSLS + $\Delta$ MSLS

An execution example is shown in Figure 14.17. After the execution, a file named MFBANK26\_0.spec is generated. This file stores little endian 26 dimensional vector sequence expressed in the 32 bit floating-point number format. When separation cannot be performed well, check if the f101b001.wav files are in the data directory.

```
> ./demo.sh 2
UINodeRepository::Scan()
Scanning def /usr/lib/flowdesigner/toolbox
done loading def files
loading XML document from memory
done!
Building network :MAIN
```

Figure 14.17: Execution example

Twelve modules are included in this sample. There are three modules in MAIN\_LOOP (iterator) and nine modules in MAIN (subnet). MAIN (subnet) and MAIN\_LOOP (iterator) are shown in 14.18 and 14.19. As an outline of the processing, it is simple network configuration in which acoustic features are calculated in MSLSExtraction with the audio waveforms collected in the AudioStreamFromWave module and are written in SaveFeatures . Since MSLSExtraction requires the outputs of the mel-scale filter bank and power spectra for calculation of MSLS, the collected audio waveforms are analyzed by MultiFFT and their data type are converted by MatrixToMap and PowerCalcForMap , and then processing to obtain outputs of the mel-scale filter bank is performed by MelFilterBank . MSLSExtraction reserves a storing region for the  $\delta$  MSLS coefficient other than the MSLS coefficient and outputs vectors that are double of the values specified in the FBANK\_COUNT property of MSLSExtraction as a feature. zero is in the storing region for the  $\delta$  MSLS coefficient. The  $\delta$  MSLS coefficient is calculated and stored with Delta . SaveFeatures saves the input FEATURE. The localization result from the front generated by ConstantLocalization is gave to SOURCES.

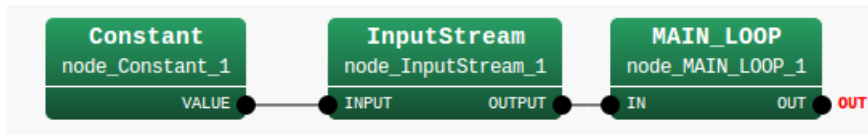

Figure 14.18: MAIN (subnet)

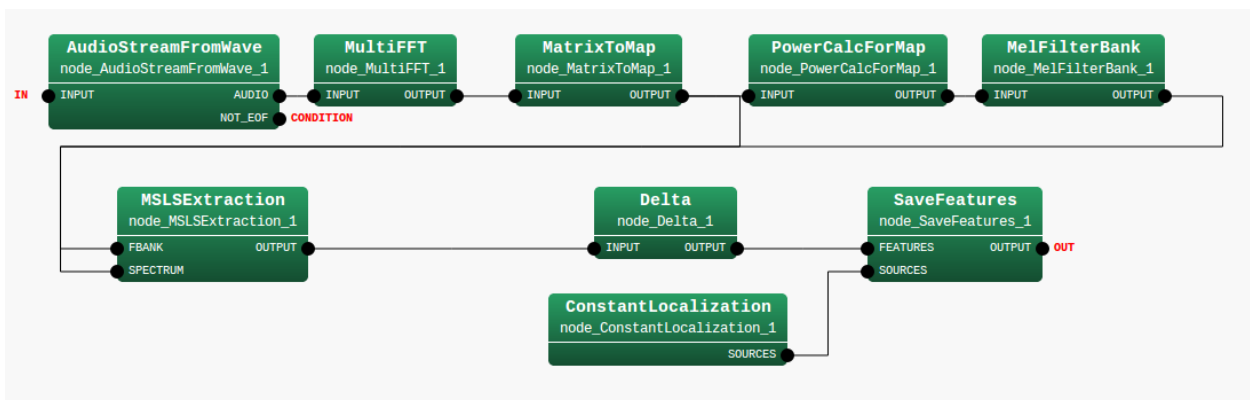

Figure 14.19: MAIN\_LOOP (iterator)

Table 14.14 summarizes the main parameters

### 14.5.4 MSLS+Power

An execution example is shown in Figure 14.20. After the execution, a file named MFBANK14\_0.spec is generated. This file stores little endian 14 dimensional vector sequence expressed in the 32 bit floating-

Table 14.14: Parameter list

Node name	Parameter name	Type	Value
MAIN_LOOP	LENGTH	subnet_param	int :ARG2
	ADVANCE	subnet_param	int :ARG3
	SAMPLING_RATE	subnet_param	int :ARG4
	FBANK_COUNT	subnet_param	int :ARG5
	DOWHILE	bool	(empty)
Delta	FBANK_COUNT	subnet_param	FBANK_COUNT

point number format. When separation cannot be performed well, check the following items, check if the f101b001.wav is in the ../data directory.

```
> ./demo.sh 3
UINodeRepository::Scan()
Scanning def /usr/lib/flowdesigner/toolbox
done loading def files
loading XML document from memory
done!
Building network : MAIN
```

Figure 14.20: Execution example

Twelve modules are included in this sample. There are three modules in MAIN\_LOOP (iterator) and nine modules in MAIN (subnet). MAIN (subnet) and MAIN\_LOOP (iterator) are shown in 14.21 and 14.22. As an outline of the processing, it is simple network configuration in which acoustic features are calculated in MSLSExtraction with the audio waveforms collected in the AudioStreamFromWave module and are written in SaveFeatures. Since MSLSExtraction requires the outputs of the mel-scale filter bank and power spectra for calculation of MSLS, the collected audio waveforms are analyzed by MultiFFT and their data type are converted by MatrixToMap and PowerCalcForMap, and then processing to obtain outputs of the mel-scale filter bank is performed by MelFilterBank. Here, the USE\_POWER property of MSLSExtraction is set to true and to output the power term at the same time. MSLSExtraction reserves a storing region for the  $\delta$  MSLS coefficient other than the MSLS coefficient and outputs vectors as a feature (zero is in the storing region for the  $\delta$  MSLS coefficient). Since the USE\_POWER property is set to true, a storing region of  $\delta$  MSLS and the delta power term is secured for the  $\delta$  coefficient. Therefore, vectors that are double of the values specified in the FBANK\_COUNT property of MSLSExtraction +1 are output as a feature. Outputs other than the necessary MSLS coefficient and item power term are deleted in FeatureRemover. SaveFeatures saves the input FEATURE. The localization result from the front generated by ConstantLocalization is gave to SOURCES.

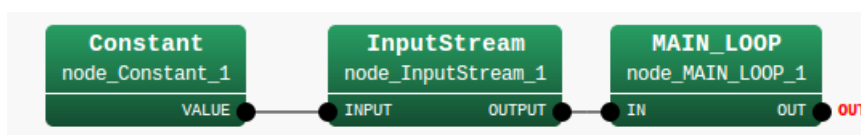

Figure 14.21: MAIN (subnet)

Table 14.15 summarizes the main parameters.

Table 14.15: Parameter list

Node name	Parameter name	Type	Value
MAIN_LOOP	LENGTH	subnet_param	int :ARG2
	ADVANCE	subnet_param	int :ARG3
	SAMPLING_RATE	subnet_param	int :ARG4
	FBANK_COUNT	subnet_param	int :ARG5
	DOWHILE	bool	(empty)
MSLSExtraction	FBANK_COUNT	subnet_param	FBANK_COUNT
	NORMALIZE_MODE	string	Cepstral
	USE_POWER	bool	true

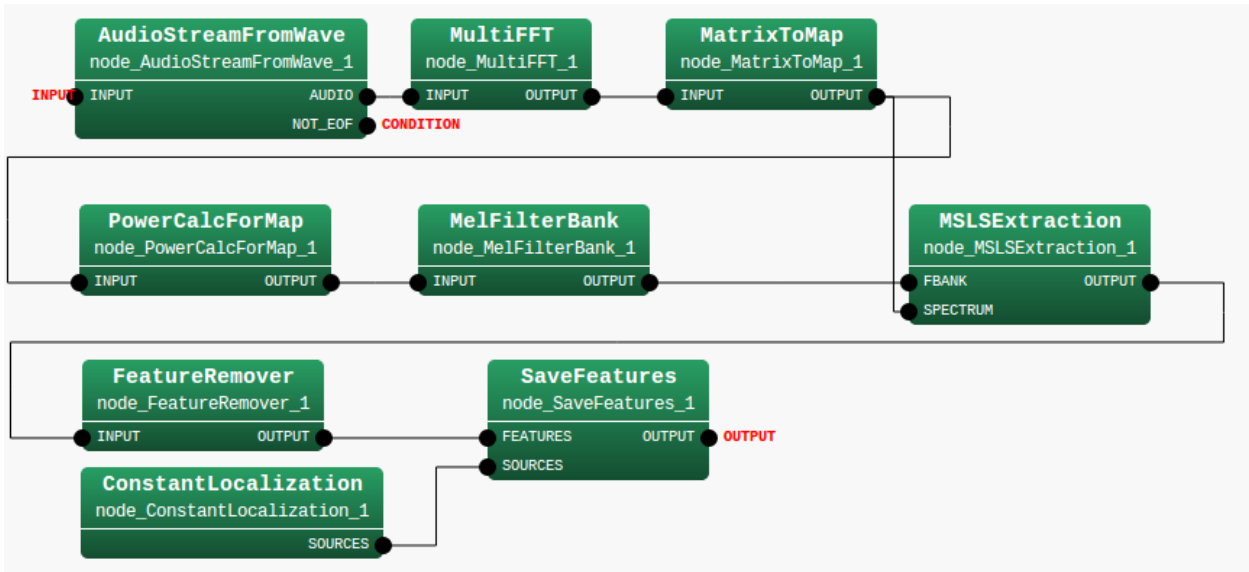

Figure 14.22: MAIN\_LOOP (iterator)

### 14.5.5 MSLS+ $\Delta$ MSLS+Power+ $\Delta$ Power

Execute `demo4.sh` in the FeatureExtraction directory. An execution example is shown in Figure 14.23. After the execution, a file named `MFBANK28_0.spec` is generated. This file stores little endian 28 dimensional vector sequence expressed in the 32 bit floating-point number format. When separation cannot be performed well, check if the `f101b001.wav` files are in the data directory.

```
> ./demo.sh 4
UINodeRepository::Scan()
Scanning def /usr/lib/flowdesigner/toolbox
done loading def files
loading XML document from memory
done!
Building network : MAIN
```

Figure 14.23: Execution example

Twelve modules are included in this sample is dozen. There are three modules in MAIN\_LOOP (iterator) and nine modules in MAIN (subnet). MAIN (subnet) and MAIN\_LOOP (iterator) are shown in 14.24 and 14.25. As an outline of the processing, it is simple network configuration in which acoustic features are calculated in MSLSExtraction with the audio waveforms collected in the AudioStreamFromWave module and are written in SaveFeatures . Since MSLSExtraction requires the outputs of the mel-scale filter bank and power spectra for calculation of MSLS, the collected audio waveforms are analyzed by MultiFFT and their data type are converted by MatrixToMap and PowerCalcForMap , and then processing to obtain outputs of the mel-scale filter bank is performed by MelFilterBank . Here, the USE\_POWER property of MSLSExtraction is set to true and to output the power term at the same time. MSLSExtraction reserves a storing region for the  $\delta$  MSLS coefficient other than the MSLS coefficient and outputs vectors as a feature (zero is in the storing region for the  $\delta$  MSLS coefficient). Since the USE\_POWER property is set to true, a storing region of  $\delta$  MSLS and the delta power term is secured for the  $\delta$  coefficient. Therefore, vectors that are double of the values specified in the FBANK\_COUNT property of MSLSExtraction +1 are output as a feature. The  $\delta$  MSLS coefficient and delta power term are calculated and stored with Delta . SaveFeatures saves the input FEATURE. The localization result from the front generated by ConstantLocalization is gave to SOURCES.

Table 14.16 summarizes the main parameters.

### 14.5.6 MSLS+ $\Delta$ MSLS+ $\Delta$ Power

An execution example is shown in Figure 14.26. After the execution, a file named `MFBANK27_0.spec` is generated. This file stores little endian 27 dimensional vector sequence expressed in the 32 bit floating-point

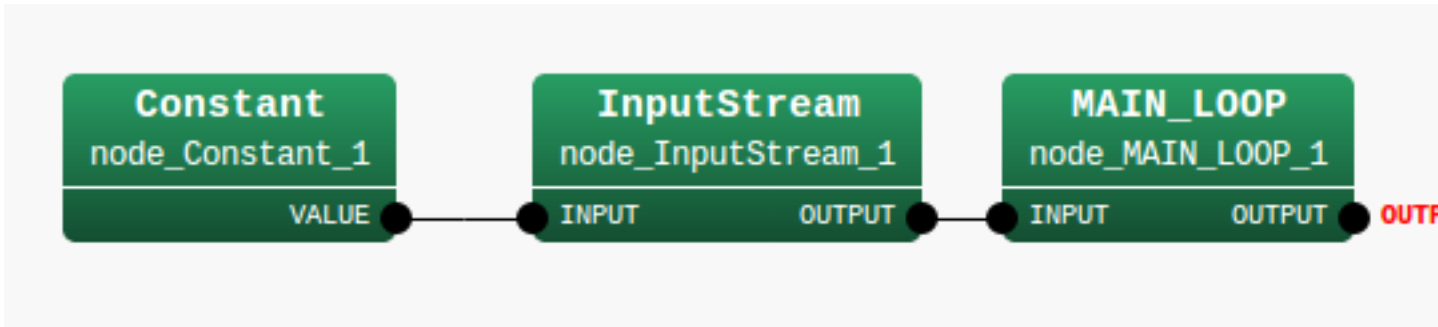

Figure 14.24: MAIN (subnet)

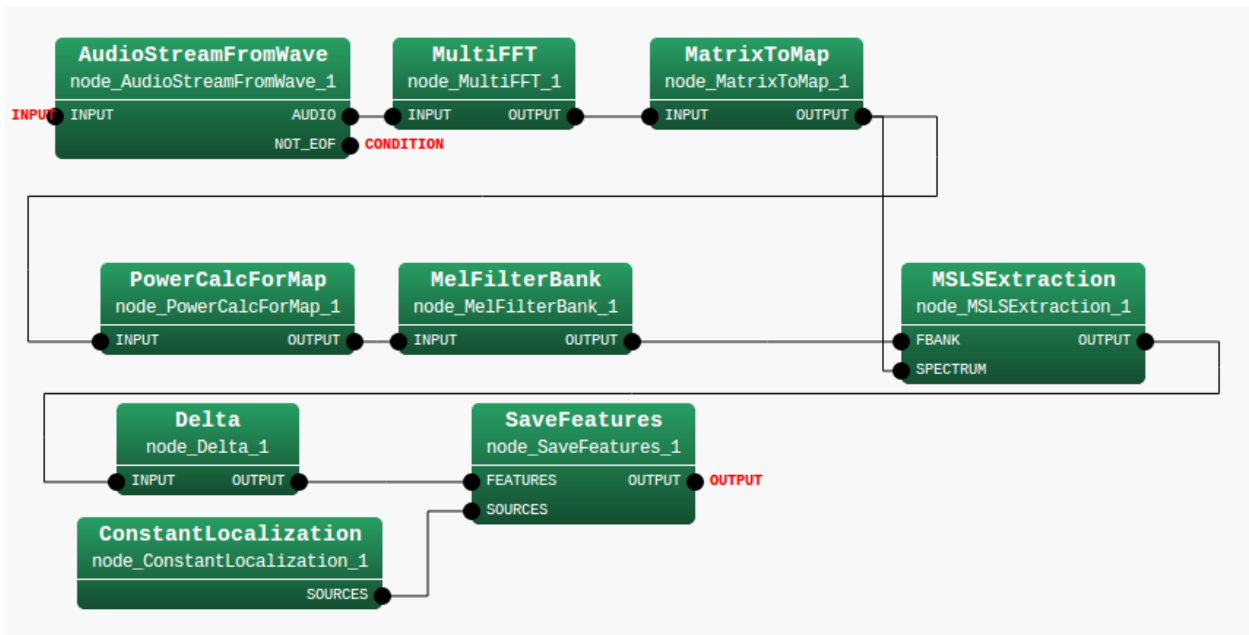

Figure 14.25: MAIN\_LOOP (iterator)

Table 14.16: Parameter list

Node name	Parameter name	Type	Value
MAIN_LOOP	LENGTH	subnet_param	int :ARG2
	ADVANCE	subnet_param	int :ARG3
	SAMPLING_RATE	subnet_param	int :ARG4
	FBANK_COUNT	subnet_param	int :ARG5
	FBANK_COUNT1	subnet_param	int :ARG6
	DOWHILE	bool	(empty)
MSLSExtraction	FBANK_COUNT	subnet_param	FBANK_COUNT
	NORMALIZE_MODE	string	Cepstral
	USE_POWER	bool	true
Delta	FBANK_COUNT1	subnet_param	FBANK_COUNT1

number format. When feature extraction cannot be performed well, check if the f101b001.wav files are in the data directory.

Thirteen modules are included in this sample. There are three modules in MAIN\_LOOP (iterator) and ten modules in MAIN (subnet). MAIN (subnet) and MAIN\_LOOP (iterator) are shown in Figures 14.27 and 14.28. As an outline of the processing, it is simple network configuration in which acoustic features are calculated in MSLSExtraction with the audio waveforms collected in the AudioStreamFromWave module and are written in SaveFeatures. Since MSLSExtraction requires the outputs of the mel-scale filter bank and power spectra for calculation of MSLS, the collected audio waveforms are analyzed by MultiFFT and their

```

> ./demo.sh 5
UINodeRepository::Scan()
Scanning def /usr/lib/flowdesigner/toolbox
done loading def files
loading XML document from memory
done!
Building network :MAIN

```

Figure 14.26: Execution example

data type are converted by `MatrixToMap` and `PowerCalcForMap`, and then processing to obtain outputs of the mel-scale filter bank is performed by `MelFilterBank`. `MSLSExtraction` reserves a storing region for the  $\delta$  MSLS coefficient other than the MSLS coefficient and outputs vectors as a feature (zero is in the storing region for the  $\delta$  MSLS coefficient). Since the `USE_POWER` property is set to `true`, a storing region of  $\delta$  MSLS and the delta power term is secured for the  $\delta$  coefficient.

Therefore, vectors that are double of the values specified in the `FBANK_COUNT` property of `MSLSExtraction` +1 are output as a feature. The  $\delta$  MSLS coefficient and delta power term are calculated and stored with `Delta`. Since necessary coefficients are the MSLS coefficient and  $\delta$  MSLS coefficient and delta power term, it is necessary to delete unnecessary power terms. Use `FeatureRemover` to delete them. `SaveFeatures` saves the input `FEATURE`. The localization result from the front generated by `ConstantLocalization` is gave to `SOURCES`.

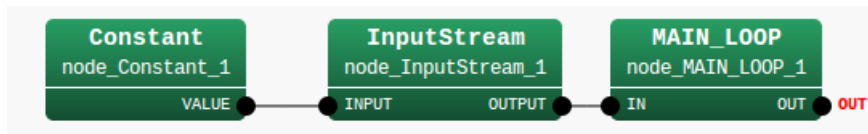

Figure 14.27: MAIN (subnet)

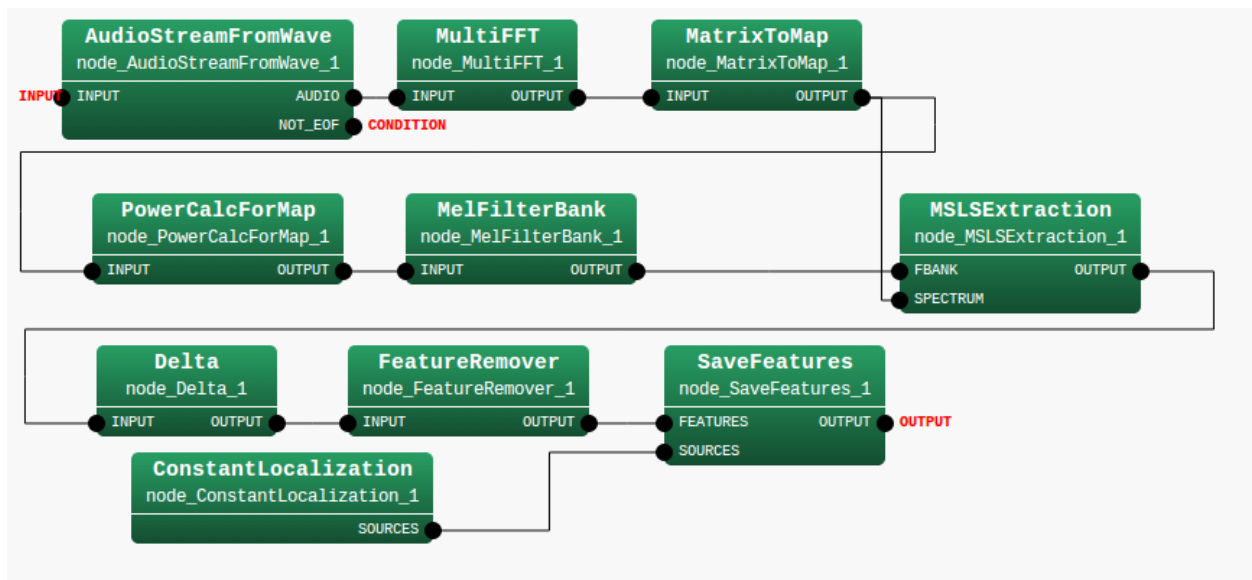

Figure 14.28: MAIN\_LOOP (iterator)

Table 14.17 summarizes the main parameters.

### 14.5.7 MSLS+ $\Delta$ MSLS+ $\Delta$ Power+Preprocessing

An execution example is shown in Figure 14.29. After the execution, a file named `MF BANK27p_0.spec` is generated. This file stores little endian 27 dimensional vector sequence expressed in the 32 bit floating-point

Table 14.17: Parameter list

Node name	Parameter name	Type	Value
MAIN_LOOP	LENGTH	subnet_param	int :ARG2
	ADVANCE	subnet_param	int :ARG3
	SAMPLING_RATE	subnet_param	int :ARG4
	FBANK_COUNT	subnet_param	int :ARG5
	FBANK_COUNT1	subnet_param	int :ARG6
	DOWHILE	bool	(empty)
MSLSExtraction	FBANK_COUNT	subnet_param	FBANK_COUNT
	NORMALIZE_MODE	string	Cepstral
	USE_POWER	bool	true
Delta	FBANK_COUNT1	subnet_param	FBANK_COUNT1
FeatureRemover	SELECTOR	Object	<Vector<float> 13>

number format. When feature extraction cannot be performed well, check if the f101b001.wav is in the data directory.

```
> ./demo.sh 6
UINodeRepository::Scan()
Scanning def /usr/lib/flowdesigner/toolbox
done loading def files
loading XML document from memory
done!
Building network : MAIN
```

Figure 14.29: Execution example

Seventeen modules are included in this sample. There are three modules in MAIN\_LOOP (iterator) and fourteen modules in MAIN (subnet). MAIN (subnet) MAIN (subnet) and MAIN\_LOOP (iterator) are shown in Figures 14.30 and 14.31 As an outline of the processing, it is simple network configuration in which acoustic features are calculated in MSLSExtraction with the audio waveforms collected in the AudioStream-FromWave module and are written in SaveFeatures . Since pre-emphasis is performed for over the time domain, after analyzing audio waveforms in MultiFFT , their type is converted with MatrixToMap and the signals are synthesized by Synthesize once. Pre-emphasis is performed for the synthesized waves with Pre-Emphasis , they are analyzed with MultiFFT once more, their type is converted with PowerCalcForMap and sent to MSLSExtraction . Since MSLSExtraction requires the outputs of the mel-scale filter bank and power spectra for calculation of MSLS, the collected audio waveforms are analyzed by MultiFFT and their data type are converted by MatrixToMap and PowerCalcForMap , and then processing to obtain outputs of the mel-scale filter bank is performed by MelFilterBank . MSLSExtraction reserves a storing region for the  $\delta$  MSLS coefficient other than the MSLS coefficient and outputs vectors as a feature (zero is in the storing region for the  $\delta$  MSLS coefficient). Since the USE\_POWER property is set to true, a storing region of  $\delta$  MSLS and the delta power term is secured for the  $\delta$  coefficient. herefore, vectors that are double of the values specified in the FBANK\_COUNT property of MSLSExtraction +1 are output as a feature. Pssing through SpectralMeanNormalization , which performs mean subtraction, the  $\delta$  MSLS coefficient and delta power term are calculated and stored with Delta . Since necessary coefficients are the MSLS coefficient and  $\delta$  MSLS coefficient and delta power term, it is necessary to delete unnecessary power terms. Use FeatureRemover to delete them. SaveFeatures saves the input FEATURE. The localization result from the front generated by ConstantLocalization is gave to SOURCES.

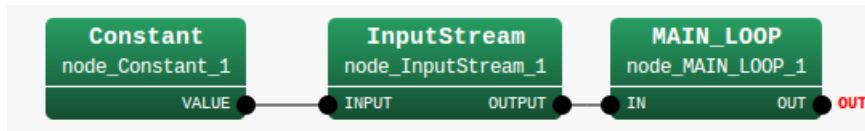

Figure 14.30: MAIN (subnet)

Table 14.18 summarizes the parameters of the network. Its main modules are PreEmphasis , MSLSExtraction , SpectralMeanNormalization , Delta , and FeatureRemover . see HARK document for details.

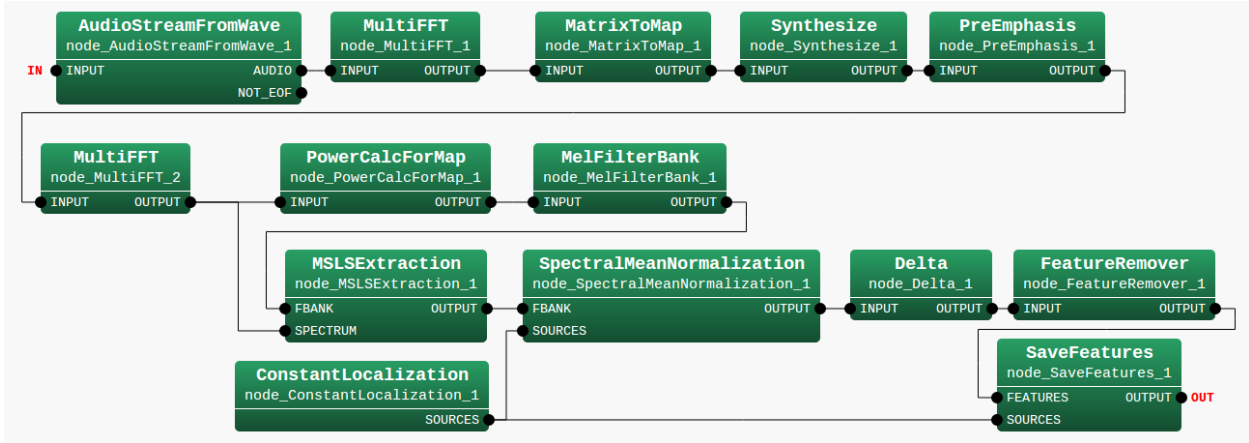

Figure 14.31: MAIN\_LOOP (iterator)

Table 14.18: Parameter list

Node name	Parameter name	Type	Value
Constant	VALUE	subnet_param	int :ARG1
MAIN_LOOP	LENGTH	subnet_param	int :ARG2
	ADVANCE	subnet_param	int :ARG3
	SAMPLING_RATE	subnet_param	int :ARG4
	FBANK_COUNT	subnet_param	int :ARG5
	FBANK_COUNT1	subnet_param	int :ARG6
	DOWHILE	bool	(empty)
PreEmphasis	LENGTH	subnet_param	LENGTH
	SAMPLING_RATE	subnet_param	SAMPLING_RATE
	PREEMCOEFF	float	0.97
	INPUT_TYPE	string	WAV
MSLSExtraction	FBANK_COUNT	subnet_param	FBANK_COUNT
	NORMALIZE_MODE	string	Cepstral
	USE_POWER	bool	true
SpectralMeanNormalization	FBANK_COUNT1	subnet_param	FBANK_COUNT1
Delta	FBANK_COUNT1	subnet_param	FBANK_COUNT1
FeatureRemover	SELECTOR	Object	<Vector<float> 13>

## 14.6 Speech recognition network sample

This section introduces the sample including speech separation, recognition, and success rate evaluation. Although the samples are for off-line use, you can use it for online processing just replacing `AudioStreamFromWave` to `AudioStreamFromMic`. All sample files are in `Recognition` directory. See Table 14.6.1 for details. The rest of this section describes how to run the samples step-by-step.

Table 14.19: The list of files

Category	File name	Description
Data	<code>../MultiSpeech_en.wav</code>	Wave file used in this sample
JuliusMFT	<code>julius.jconf</code> <code>AM/hmmdefs_en.bin</code> <code>AM/allTriphones_en</code> <code>LM/order.*</code>	Configuration file of JuliusMFT Acoustic model of English pronunciation List of triphones in the acoustic model Grammar-based language model
HARK	<code>Recognition_en.n</code> <code>Recognition.sh</code> <code>../config/microcone_tf.zip</code> <code>sep_files</code>	HARK network file for localization, separation, and feature extraction Shell script to run the network file Transfer function for localization and separation (for HARK 2.1.0 or later) Directory for separated sounds
Evaluation	<code>score.py</code> <code>transcription_A.txt</code> <code>transcription_B.txt</code>	Evaluation script Reference data of the utterances for each direction Reference data of the utterances for each direction

### 14.6.1 Running the speech recognition

Prepare two terminals. Run speech recognition using JuliusMFT in one terminal, and run speech separation using HARK in another terminal. The commands and results are shown in Figs. 14.32 and 14.33, respectively. Note that you need run JuliusMFT first to make sure that the separated sound is sent after the initialization of JuliusMFT. After the separation, you will find wave files in `sep_files/` directory, and a `result.txt`, a speech recognition log file.

```
> 1_Julius.sh
After you see the message "waiting client at 10500",
press enter again [Press Enter]

<-- You press enter

STAT: include config: julius.jconf
STAT: loading plugins at "/usr/lib/julius_plugin":
STAT: file: calcmix_heu.jp1 #0 [Gaussian calculation plugin for Julius.
                                (ADD_MASK_TO_HEU)]

... skipped ...
////////////////////
///  Module mode ready
///  waiting client at 10500
////////////////////

<-- You press enter again.
```

Figure 14.32: An execution example of JuliusMFT

The wave files are the separated sound to be recognized. Since these wave files are standard monaural audio files, you can listen to them by your audio player.

The text file `result.txt` is a raw speech separation log.

#### Trouble shooting

If no wave files are created, it means that HARK does not work correctly. Check if you have all files listed in Table , and `sep_files/` directory is writable. Next, check if you successfully installed HARK (See the recipe 3.1Installation fails for this.)

If `result.txt` includes no recognition result, it means that JuliusMFT does not work. Check if JuliusMFT is installed. Run `julius_mft` in your terminal. If you see `command not found`, it is not installed yet. Next, check if all files listed in Table exist. Finally, check if you typed exactly the same command shown in Fig. 14.32.

For any case, the reason of the error will be written in log file or error messages. Read them carefully.

```

> 2_Recognition.sh
UINodeRepository::Scan()
Scanning def /usr/local/lib/flowdesigner/toolbox
done loading def files
loading XML document from memory
done!
Building network :MAIN
TF = 1,INITW = 0,FixedNoise = 0
SSMethod = 2LC_CONST = OLC_Method = 1
reading A matrix
72 directions, 8 microphones, 512 points
done
initialize
Source 0 is created.
Source 1 is created.
... skipped ...

```

Figure 14.33: An execution example of HARK

## 14.6.2 Evaluating the speech recognition

The next step is to evaluate the success rate of speech recognition using an evaluation script `score.py`.

```
> 3_Evaluation.sh
```

Each argument of the python script means that a speech recognition log, a reference data, a sound direction, and a tolerance.

After you run the script, you will see the result like Fig. 14.34. Starting from the left, each row means that the recognition is succeed or not, recognition result, and the reference. The last line means the overall success rate. In this case, 33 utterances out of 40 utterances are successfully recognized, consequently, the success rate us 85%.

ground truth	recognition result	status
"pork-cutlet-bowl"	""	Deletion
"curry-and-rice"	""	Deletion
"beef-bowl"	"beef-bowl"	Correct
"seafood-salad"	"seafood-salad"	Correct
"scrambled-eggs"	"scrambled-eggs"	Correct
"beef-bowl"	(skipped)	
	"beef-bowl"	Correct
33 / 40 (82.5 %)		

Figure 14.34: Recognition result.

For any directions, the success rates should be around 80%. If the rate is extremely low, check if you specified the correct pair of a direction and a reference data. If the rate is still low, the separation or recognition may fail. Listen to the files in `sep_files/` to check if the separation is succeeded, or refer to the recipes in Chapter 3.